

FRIZLEN
POWER RESISTORS

T600



Steel-grid fixed resistors

THE ROBUST ONES

**Dynamics
through
resistance**

FRIZLEN GMBH U. CO KG.
POSTFACH 424
D-71712 MURR
TELEFON +49 (0) 7144/8100-0
TELEFAX +49 (0) 7144/207630

GOTTLIEB-DAIMLER-STRASSE 61
D-71711 MURR
email: info@frizlen.com
Internet: www.frizlen.com

Dynamics through resistance – Our products

T100 THE ORIGINAL ONES 10 up to 6000 Watt

Wirewound tubular fixed and slide resistors as individual components, that can be integrated into other units and composed to tubular fixed units in different degrees of protection and mounting types.

- in cemented and uncemented version – variable connections at soldering, fast-on or screw clips, with or without adjustable clips
- units consisting of one to six tubes
- in degree of protection IP00 with threaded rod, fastening brackets or side-panels
- in degree of protection IP20 with enclosure for horizontal and vertical mounting, connection on terminals
- thermal overload relay or temperature switch for thermal monitoring

T200 THE FLEXIBLE ONES 16 up to 1500 Watt

Cement coated wirewound potentiometers as individual components, that can be integrated into other units, combined together and fitted with motor, switches etc.

- in single version, with additional micro switches, with scale discs and adjusting knobs
- in in-line configuration, for multiple phases or switched in parallel
- integrated in enclosure or dustproof encapsulated
- motor driven, for different AC and DC operating voltages and operating times, with micro switches, also with precision ten turn potentiometer

T300 THE INNOVATIVE ONES 5 up to 4000 Watt

Wirewound flat resistors as individual components in an open design that can be integrated into other units and composed to encapsulated flat resistor units in different degrees of protection and mounting types

- with hard soldered wires or soldering lugs, if enclosed connection to wires or terminals
- in degree of protection IP00 single elements can be combined to units for special requirements
- up to degree of protection IP67 for horizontal and vertical mounting
- up to degree of protection IP54 in multiple configuration for higher continuous dissipation

T500 THE MODULAR ONES 0,15 up to 30 Kilowatt

Wirewound lamina type fixed resistors as individual components, that can be integrated into other units and composed lamina type fixed resistor units in different degrees of protection and mounting types.

- variable connections at wires, screw clips or terminals, with or without adjustable clips
- in degree of protection IP00 single elements can be combined to units for special requirements
- up to degree of protection IP20 or IP23 for horizontal and vertical mounting
- thermal overload relay or temperature switch for thermal monitoring

T600 THE ROBUST ONES 0,5 up to 250 Kilowatt

Steel-grid fixed resistors as individual components, that can be integrated into other units and composed to steel-grid fixed resistor units in different degrees of protection and mounting types.

- with or without cover, connection direct to the resistor or on terminals in degree of protection IP00, IP20 or IP23
- for horizontal and vertical mounting and for integration into exhaust air installations
- thermal overload relay or temperature switch for thermal monitoring
- forced ventilation for higher dissipation, switching in parallel of units for dissipation >250kW

Applications:	Leistung		Liste T				
	von	- bis	100	200	300	500	600
braking resistors for frequency converters and DC drives	5	- 4,0 kW	X		X	X	
	0,3	- 6,0 kW	X			X	X
	6,0	- 30,0 kW				X	X
	30,0	- 250 kW					X
load resistors for supply units, power packs, batteries, UPS units and generators	0,01	- 4,0 kW	X	X	X		
	0,15	- 30 kW	X			X	
	0,5	- 250 kW					X
stepless variable adjustment for small AC and DC motors	16	- 1500 W		X			
field rheostats for generators, resistors for current and voltage limitation	0,01	- 3,8 kW	X	X			
motorised potentiometers as nominal value setter	16	- 1500 W		X			
resistor modules fitting in electronic power devices	5	- 750 W	X		X	X	
	0,3	- 2,0 kW				X	
starting and regulating resistors for slip-ring rotor and DC motors	0,15	- 30,0 kW				X	
	0,5	- 250 kW					X
stator series resistors for squirrel-cage motors	0,5	- 250 kW					X
resistors for current limitation e.g. for charging and discharging of capacitors	10	- 1000 W	X		X	X	
resistors for experimenting and testing in laboratories, schools and universities	0,01	- 3,8 kW	X	X			
protective resistors, filter resistors	10	- 750 W	X		X	X	
	0,75	- 6,0 kW	X			X	X



Contents

This list comprises steel-grid fixed resistors as individual components in the production series S, as well as resistor blocks in the series FE and FK.. that can be integrated into other units and composed to steel-grid fixed units in different degrees of protection and mounting types

<i>maximum typical power</i>	<i>characteristics</i>	<i>type series</i>	<i>page</i>
	general survey		T612E
	technical details		T613E
0,5 kW	suitable for integration, individual elements	S 1 – S 30	T620E
22 kW	suitable for integration, with threaded bolt M12	FE 31..	T621E
22 kW	suitable for integration, with flat side-panel end plates	FKE 31..	T622E
22 kW	flat construction form, 2 terminals, various types	FGF.. 31..	T623E
12 kW	for switch cabinet, 2 terminals	FGHD.. 31..	T625E
66 kW	for integration with great rated power	FK 3..	T626E
250 kW	in canal construction	FKK 3..	T627E
66 kW	for floor mounting, also IP 23	FA 3../FS 3..	T628E
5,0 kW	for wall mounting, IP 23	FS 319.. / 320..	T629E
250 kW	various wattage rating, with forced ventilation	FSV 3.. / FAV 3..	T630E

Properties

- **very favourable price-performance-ratio**
⇒ high power, high quality and low budget
- **individual components in 30 different resistor element values**
⇒ high ampacity up to 122 A per steel-grid fixed resistor, may be enlarged by switching in parallel
- **lower temperature coefficient than cast iron resistors**
⇒ therefore smaller dependence of the resistor value on temperature than cast iron resistors
- **high heat capacity**
⇒ overload resistant at short time load
- **very robust construction**
⇒ insensitive to vibrations
- **enclosures made from hot galvanised steel sheet**
⇒ various protection and mounting types (all series besides S and FE)
- **temperature switch available**
⇒ integrated warning for temperature monitoring (optional with many series)
- **thermal overload relay available**
⇒ integrated warning for high operating security (serialized with series FGFT)
- **UL-recognition for American and Canadian market (E212934)**
⇒ on request for all marked series available



Applications

- braking resistors for frequency converters and DC drives as well as railway applications
- load resistors for emergency power supply units, generators, motors and electronic power sources
- starting resistors for DC motors
- stator resistors for squirrel-cage motor
- starting and regulating resistors for slip-ring rotor motor
- discharge resistors for batteries
- earthing resistors for low-voltage mains supplies



T 600 – Survey

type series		S 1 - S 30	FE. 31..	FKE. 31..	FGF.. 31..	FGHD. 31..	FK. 3..	FKK. 3..	FA./ FS. 3..	FS 319.. - 320..	F.V 3..
characteristics	page symbol	620E	621E	622E	623E 624E	625E	626E	627E	628E	629E	630E
typical power from [kW]		0,5	1,0	1,0	1,0	1,0	1,5	5,0	1,5	0,5	70
typical power up to [kW]		0,5	22	22	22	12	66	250	66	5,0	250
max. number of terminals (without temperature switch)		-	-	-	2	2	40	6	40	2	40
degree of protection IP00	IP 00	X	X	X			X	X			
degree of protection IP20 - if mounted on an appropriate surface	IP 20 ^①				X	X					
degree of protection IP20	IP 20								X		X
degree of protection IP23	IP 23								X	X	X
horizontal mounting		X	X	X	X		X	X	X		X
vertical mounting		X	X	X	X	X		X		X	
temperature switch (optional)			X	X	X	X	X	X	X		
thermal overload relay					X						
connection at lugs at the resistor		X	X	X							
integration possible	E	X	X	X		X	X				
with forced ventilation											X
with recognition		X	X	X	X	X	X		X		

Rights for improvements and modifications of our products reserved.
 Modifications, errors and misprints justify no claim for damages.
 We refer to our terms of sales and delivery.



Technical details

Construction
Steel-grid fixed resistor elements
Type series S

Our steel-grid fixed resistor elements (SG) are made from chromium alloyed and heat-resistant steel sheets of alloy X10CrAl13 (material # 1.4724) which are of a high specific resistance value. Both long sides of the SG are perforated with slots in a meander-shaped current path. The ohmic value depends on the width of the straps. They are mechanically reinforced by strips of stainless steel with inlays of mica.

Spectrum

By the use of SG with a big ohmic range of $0,022 \Omega$ to $5,6 \Omega$ and a typical power of 500 W per steel-grid we can reach a wide range of resistance value and power by variation of steel-grid number and ohmic value.

Resistance values/
Production tolerance/
Temperature dependency

Steel-grid fixed resistor elements have a smaller dependence of the resistance value on the steel-grid temperature than cast iron resistors, however a noticeably higher one than wire-wound resistors. The resistance value increases approx. 15% between cold and operating temperature.

The given rated resistance values of each individual SG in the table on page T620 are about 8% higher than the resistance value in cold condition and about 7% below the resistance value at the operating temperature.

The production tolerance is $\pm 10\%$.

Energy absorption capacity/
Time constant

The energy absorption capacity varies per SG at a temperature increase of 300 K in dependency of the ohmic value between 50 and 70 kW.

The average thermal time constant is 100 s.

Resistor blocks
Type series FE

If larger power ratings are to be obtained, several SG are assembled by M12-thru bolts and isolating mica tubes to a resistance block. The isolation between 2 neighbouring SG is effected by glazed ceramic rolls, the current conduction by stainless steel rolls. The resistance block is prestressed by cup springs and so held under constant contact pressure. In addition to that individually screwed conductor rolls between two neighbouring SG are possible. A resistor block may consist of identical SG or of different SG with lugs as taps.

Resistors
Type series FK; FGF; FA; FS

In order to facilitate the integration, and/or to provide different degrees of protection, various kinds of enclosures are used. The enclosures are manufactured from hot-galvanized and perforated steel sheet and therefore are well protected against corrosion. Also an extra varnish in RAL 7032 is available with an additional charge as well as enclosures in stainless steel (alloy 1.4301).

Degrees of protection

Correlation of type series and degrees of protection according to EN 60529 and/or DIN VDE 0470 part 1

IP
00

IP
20^①

IP
20

IP
23

Type series	Degree of protection	First characteristic numeral degree of protection against access & solid foreign objects	Second characteristic numeral degree of protection against water
S FE FK..	IP 00	Non-protected – i.e. depending upon integration the user must provide a protection	Non-protected
FGF..	IP 20 ^①		Non-protected
FA..	IP 20	Protected against access to hazardous parts with a finger and against solid foreign objects of 12,5mm \varnothing and greater.	Non-protected
FS..	IP 23		Protected against spraying water. Water sprayed at an angle up to 60° on either side of the vertical shall have no harmful effects. (for outdoor location)

^① if mounted on an appropriate surface – i.e. mounted on a surface according to degree of protection IP 20 or higher



Protective measures



All our power resistors with degree of protection IP 20^① or higher correspond to safety class system I, i.e. we provide connections for protective earth conductors according to EN 61140.

Devices with degree of protection IP 20 or higher correspond to the CE low voltage standardization.

Power resistors being passive electronical or electrical units are not affected by the specific EMC standards. They do not produce any interfering radiations nor are they affected.

Excess current protection

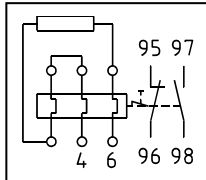

A protection of the resistors against overloading or excess temperature - as demanded in standards - can be realized with the help of a user thermal overload relay. The set current must correspond to the rated current of the resistor, that is calculated according to continuous duty power and resistance value after Ohm's law (formula: see "terminal details" p. T618E).

With the series FGFT the thermal overload relay is a component of the device with exceeding of the rated current a signal contact is released. There will not be a disconnection of the resistor. Resetting by hand.

Excess temperature protection

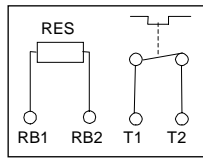

Another kind of the excess temperature monitoring, particularly suitable with long-time overloading, is the equipment with a temperature switch. With IP 20 / IP 23 - resistor devices it is wired on terminals, with IP 00 resistors the switch is directly connectable and releases a signal contact when the set temperature is exceeded. There will not be a disconnection of the resistor. See type series FE / FKE / FG / FK / FA / FS.

Contact rating

Contact ratings of the signal contacts of temperature switches and thermal overload relays.

- 2 A / 24 VDC (DC11)
- 2 A / 230 VAC (AC11)

Air und creepage distances

Air and creepage distances are rated after IEC 664 (DIN EN 0110 part 1) for the overvoltage category III and pollution degree 3 for grounded three-phase mains supplies up to 3 x 500 V. Testing voltage 2.5 kV AC.

These data are good for all devices that are connected with mains voltage and derived voltages, like for example the intermediate circuit voltage of frequency converters.

Do not conclude from the calculated relation between the rated power and the maximum producible ohmic value to the rated voltage.

UL-recognition



All important type series do have an UL- recognition both for the American and for the Canadian market. The devices were certified after UL 508 under the number E212934. This recognition is the same as a recognition according to CSA C22.2 No.14. For further information please check the UL-flyer.

(Please ask for it or visit us at www.frizlen.com)



Selection of Type series and dimension

The tables on the following data sheets contain a selection of the available equipment assemblies and/or the appropriate maximum assembly of the respective size of the device. Less steel-grids (SG) are possible.

For all type series, except for S, the following type codes are shown to explain the complete type designations.

Type code 1

FK E U 3 1 3 30 02 - 50 — ohmic value $\pm 10\%$
 — number of terminals or connecting lugs
 — # of steel-grids (e.g.: 30 SG = 15 kW)
 — construction width 1; 2; 3; 4, 5,
 — construction height 1; 2 or 3 tiers
 (with FGF..., FKE., FE. only height 1!)
 — type series 3
 — UL-construction
 — addition like E(Q); FG; FK(Q); FL(Q);
 HD(Q) u. FT - Q stands for temperature-
 switch(TS)
 — type series FK; FE; FG; FA or FS

Type code 2

FS 3 20 09 02 - 22 — ohmic value $\pm 10\%$
 — number of terminals or connecting lugs
 — # of steelgrids (e.g.: 9 SG = 4,5 kW)
 — type series 19; 20; 85; 86; 87; 88
 — type series 3
 — addition like V (only for 85 – 88)
 — type series FA or FS

Type series S represents individual components. You can see their complete type designation in the table on p. T620.



Devices that are built according to UL standard are marked additionally with "U" at the last position in the sequence of letters- see type code 1 and the following example

Selection of devices/ Example given:

- continuous power rating of the resistor: $P = 9,0 \text{ kW}$
- resistance value: $R = 27 \Omega$
- continuous current of the resistor: $I = 18 \text{ A}$
- construction with terminals that are protected against contact
- degree of protection IP 20 (mounting on switch cabinet)
- with temperature switch (TS)
- design according to UL

wanted: resistor

- number of SG = continuous power rating : power per SG = $9,0 \text{ kW} : 0,5 \text{ kW} = 18 \text{ SG}$
- selection of type series from survey on p. T612
- possible type series: FGF...; FA
- with mounting on a switch cabinet – means on a surface of degree of protection IP 20 you can choose the smaller and low priced alternative FGF, compared to type series FA. If the terminals should be in an attached terminal box, type series FGFKQ is adequate, because of the necessary temperature switch (TS)
- with 18 SG you can select within enclosure size construction height 1 and width 2 (max. poss. 24 SG)
- construction according to UL508: add "U" to the type designation,
- type designation would be FGFKQU 3121802 – 27 (with 2 device terminals up to 65 A). Type description see p. T623Eff



Short time dissipation/
Total cycle time/
Duty cycle factor(DCF)

At many applications resistors are not loaded in continuous but in short time operation. In the following you will find indications, how to calculate the allowable short time dissipation with the help of the duty cycle factor (DCF) and the overload factor (OLF). If the DCF factor is not known, it can be calculated as follows:

$$\text{Duty cycle factor(DCF)} = \frac{\text{Switch on time}(t_{on})}{\text{Total cycle time}}$$

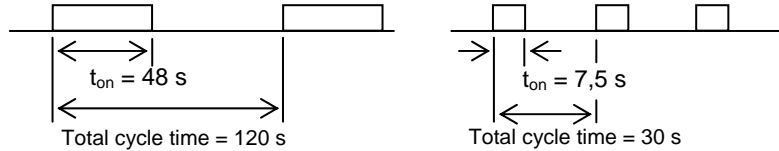

$$DCF_1 = \frac{48s}{120s} = 0,4 = 40\%$$

$$DCF_2 = \frac{7,5s}{30s} = 0,25 = 25\%$$

Warning: The total cycle time may be maximum 120 s - shorter total cycle times are possible.
The total cycle times for motors are mostly higher than 120 s

Overload factor(OLF)

By comparison of the known DCF-factor with the following diagram or table you can work out the overload factor (OLF) and/or the continuous and the short time dissipation.

Overload factor (OLF) in dependence of duty cycle factor (DCF)
(Total cycle time = 120s)

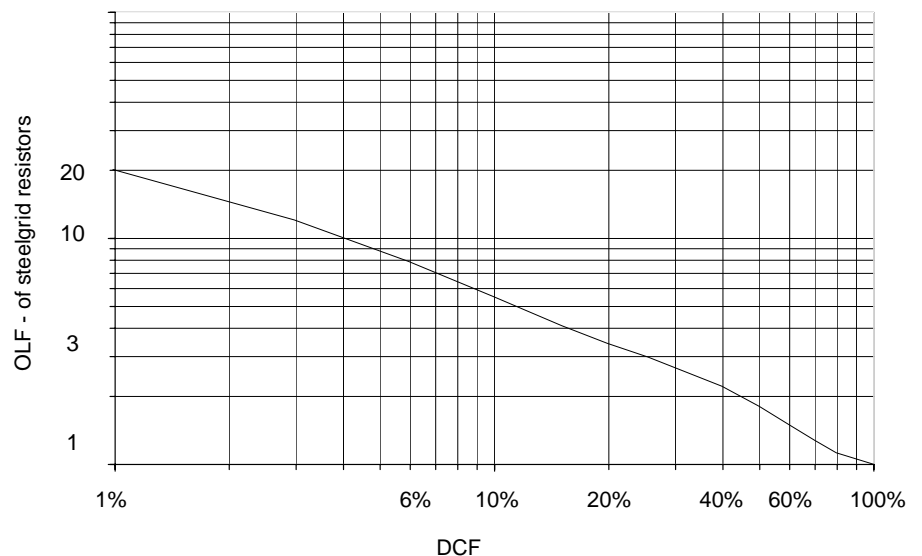

DCF	1%	3%	6%	15%	25%	40%	60%	80%	100%
OLF	20	12	7,6	4,0	3,0	2,2	1,5	1,12	1,0

The continuous and the short time dissipation can be calculated as follows:

$$\text{Short time dissipation} = \text{Continuous dissipation} \times \text{OLF}$$

$$\text{Continuous dissipation} = \frac{\text{Short time dissipation}}{\text{Overload factor(OLF)}}$$

Calculation example
given:

wanted:
continuous dissipation

- Resistor with a short time dissipation of 100 kW for 48 s and a total cycle time of 120s
- The duty cycle factor (DCF) would be 48 s : 120 s x 100% = 40%
- Overload factor (OLF) for 40% DCF, according to table it is 2,2
- The continuous dissipation is 100 kW : 2,2 = 45,5 kW;
- You would need a resistor with a continuous dissipation of at least 45,5 kW!



Typical power/ Continuous dissipation/ Ventilation / temperatures

The given typical power values are valid for 100% duty cycle factor (DCF) (continuous dissipation) under the following conditions:

- Temperature rise of 200 K at the surface of the resistor enclosure (degree of protection > IP00)
- Temperature rise of 300 K at the surface of the resistor element (degree of protection IP00)
- Maximum ambient temperature 40°C
- unhindered access of cooling air
- unhindered diverting of warmed up air (keep a minimum separation distance of approx. 200 mm to neighbouring components/walls and of approx. 300 mm to components above/ceiling)
- warning: If the ambient temperature is higher than 40°C, you have to lower the continuous dissipation for 4% per 10 K temperature rise!

Since electrical energy is converted into heat, it is inevitable that the exhaust air will be heated up, as well as the section of enclosure at the air outlet.

The highest temperature with typical power may be maximum 200°C beyond the ambient temperature. Since the cooling of the devices is accomplished by convection and/or forced ventilation (series FAV/ FSV), the above mentioned aspects have absolutely to be considered.



In a case of insufficient cooling or false mounting the resistor or the surrounding devices could be overheated or ruined.

Depending upon use it can be possible, to increase the continuous dissipation of the resistors, if higher temperatures are accepted. With increase e.g. of 130% of the typical power you will have a rise in temperature of 350K at the surface of the resistor. In other cases of applications the continuous dissipation must be reduced, for example with temperature sensitive devices in the surrounding. The dependence between temperature rise and actual continuous dissipation is shown in the diagram below.

Excess temperature in dependence of continuous dissipation

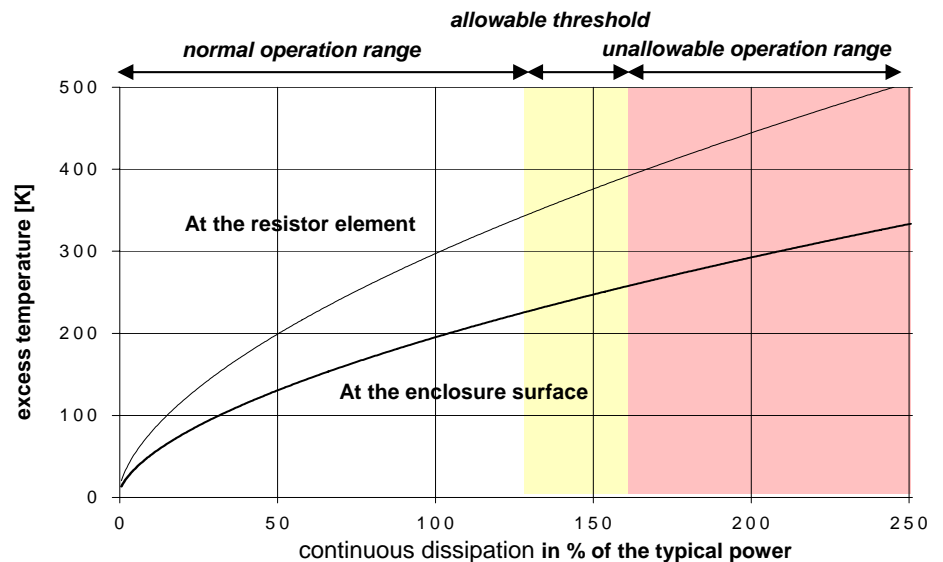

Normal operation range (up to 130%):

Recommended operation range for maximum product life and failure free operation

Allowable threshold (up to 160%):

Allowable operation range, danger of shorter product life and higher failure probability

Unallowable operation range (more than 160%):

Danger of excessive heat and destruction of resistor and neighbouring components



Terminal details

Rated current and cross section of terminals

type	abbreviation	rated current in A with 100% DCF	rated current in A up to 40% DCF	Maximum cross section
porcelain terminal	PK	16		up to 2,5 mm ²
ceramic flat terminal	FK	35	44	2,5 - 10 mm ²
device terminals out of polyamid (PA)	G 5	30	38	0,5 – 2,5 (4) mm ² AWG 24 - 12
	G 10	60	75	0,5 – 10 (16) mm ² AWG 20 - 6
bolt terminals out of ceramics	BK M6	60	75	cross section depending on lug size with corresponding hole
	BK M8	115	143	
	BK M10	220	287	
	BK M12	400	536	
feed-through terminal out of PA	HDFK4	30	38	up to 4,0 mm ² ; AWG 24 - 12
	HDFK10-HV	65	82	up to 10 mm ² ; AWG 20 - 6
cage clamp terminal out of PA	ST2,5	20	25	up to 2,5 mm ² ; AWG 26 - 12
	ST 4	30	38	up to 4,0 mm ² ; AWG 20 - 10

The rated current is calculated in each case due to the Ohm's law as follows:

$$I = \sqrt{\frac{P}{R}}$$

whereas
P is the power of the resistor and
R is the value of the resistance

Wiring

If terminals are required, the connections are wired by means of flexible, heat resistant, silicone-insulated wire on a terminal strip that is located in the lower and/or front part of the equipment within the area of the entering cooling air. For UL versions wires with UL recognition are used (other wire insulations on request).

With the series FK /FA /FS 3 as well as with F.V 38 there is an undrilled cable entry strip in the lower part. It can be provided by the user with appropriate drillings for cable glands as strain relief.

Mounting

Please mind the mounting indications in the respective series!
You will find these icons in the data sheets:



Allowable: On horizontal surfaces



Allowable: On vertical surfaces terminals at the bottom



Not allowable: On vertical surfaces terminals at the top, left or right



Dimensioning example

Braking resistor

- given:**
- Maximum intermediate circuit voltage 650V : $U_{ZK} = 650\text{ V}$
 - Smallest allowable resistance value:
(from data sheet of frequency converter) $R_{min} = 25\ \Omega$
 - maximum allowable chopper current $I = \frac{U_{ZK}}{R_{min}} = \frac{650\text{V}}{25\Omega} = 26\text{A}$
 - duty cycle factor for braking operation (corresponding to the application),
for a hoist drive e.g. 40 % DCF referring to a total cycle time of 120 s
DCF = 40%
 - degree of protection IP 20 in fixed condition
- wanted:**
- short time dissipation of the resistor with 40%DCF $P = \frac{U^2}{R} = \left(\frac{650\text{V}^2}{25\Omega}\right) = 19,6\text{kW}$
 - continuous dissipation = short time dissipation : overload factor (s. p. T616E)
 - continuous dissipation = 19,6 kW : 2,2 = 8,9 kW
 - number of steel-grids = continuous dissipation : dissipation per SG
 - number of steel-grids = 8,9 kW : 0,5 kW \approx 18 SG
- selection of steel-grids:**
- resistance value of a SG = R_{min} : SG-number = $25\ \Omega : 18 = 1,39\ \Omega$
The ohmic value should not be smaller than R_{min} altogether, since otherwise the allowable chopper current is exceeded! SG selection of p. T620E = 18 pieces
S 23 – 1,5 Ω ; total ohmic value is 27 Ω
- selection of products:**
- With degree of protection IP 20 in fixed condition – series FGFG..
 - With 18 steel-grids – construction size 312 18..
 - with 2 terminals up to 35 A, without temperature switch – type FGFG
 - The type designation would be FGFG 3121802 - 27 (s.p. T623Eff)

Dimensioning example

Load resistor

- given:**
- Rated voltage U of supply unit: $U = 3 \times 230/400\text{ V}$
 - rated dissipation: $P = 15\text{ kW}$
 - star connection, star point in the unit
 - duty cycle factor: DCF = 100%
 - degree of protection IP 23
- wanted:**
- rated current
per phase with star connection: $I_N = \frac{P_N}{\sqrt{3} \times U_N} = \left(\frac{15\text{kW}}{\sqrt{3} \times 400\text{V}}\right) = 21,7\text{A}$
 - nominal value of resistance
per phase with star connection: $R_{wanted} = \frac{U_N}{\sqrt{3} \times I_N} = \left(\frac{400\text{V}}{\sqrt{3} \times 21,7\text{A}}\right) =$
 - value of resistance in cold condition: $R_{cold} = 0,95 \times R_{wanted} = 0,95 \times 10,7\ \Omega =$
If the demanded rated dissipation is to be achieved at operating temperature in the range of the resistance tolerance, it is advisable to consider the value of resistance in cold condition.
 $R_{cold} = 0,95 \times R_{wanted}$
Then you can make your selection of steel grid.
- selection of steel-grids:**
- Selection of steel-grids of p. T620E by the rated current of 21,7 A: S 21 – 1,0 Ω
 - number of SG per phase = value of resist. in cold condition: ohmic value per SG
 - number of SG = 10,2 $\Omega : 1,0 \approx$ 10 SG per phase – 3phases is 30 S 21 – 1
 - value of resistance in cold condition is therefore 3 x 10 Ω
 - resulting rated dissipation: 3 x 10 SG per 0,5 kW = 15 kW
- selection of products:**
- with degree of protection IP 23 – series FS..
 - with 30 steel-grid fixed resistors – size 313 30.. or 322 30..
(size 313.. is lower, size 322.. is narrower)
 - with 3 terminals (star point in the unit) number of terminals ...03
with 4 terminals (star point wired on 1 terminal) number of terminals ...04
 - The type designation would be FS 313 30 03 – 3 x 10,7
(low unit, star point in the unit) (type series FS s. p. T628E)



Steel-grid fixed resistor elements S 1 – S 30

500 W for integration

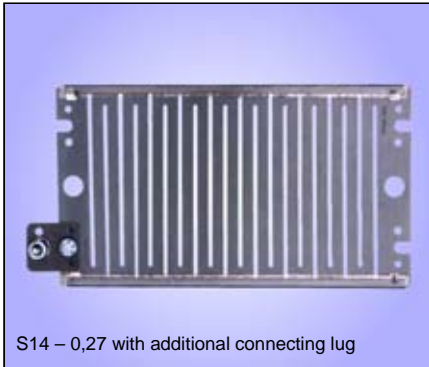

S14 – 0,27 with additional connecting lug



Steel-grid fixed resistor element, degree of protection IP 00 for integration into units. Connection at the resistor

Technologies

- particularly flat design
- overload resistant
- continuous dissipation 500 W^①
- energy absorption capacity with $\Delta T = 300\text{ K}$, from 50 up to 70 kW
- integration possible

As accessories we deliver 1 or 2 lugs to each resistor element with connection screws M10 (S 1 - S 10) or M6 (S 11 - S 30). Normally they are not fixed, we will fix them upon request.

We produce steel-grid fixed resistor elements in a wide range of resistance values of 0,022 Ω up to 5,6 Ω and a typical power of 500 W^① per grid.

The given nominal ohmic values are about 8% above the value of cold condition and 7% below the value of operating temperature. The production tolerance is $\pm 10\%$.

We achieve a wide range of resistance values and wattage rating by variation of number of steel-grids and resistance values.

Please consider the different designs and construction forms of the following series.

The indicated ratings are valid for an ambient temperature of max. 40° C at sufficient ventilation. The indicated values for the duty cycle factor (%DCF) are preferred values and refer to a maximum total cycle time of 120 s.

You will find further indications for dimensioning of a resistor for short time dissipation in chapter Technical Details pages T613E to T619E.

Electrical and mechanical data

typical power ^①	% DCF	100	60	40	25	15	6	recomm. connection screws...
	[W]	500	750	1100	1500	2000	3800	
type	Ω	Max. current in amp. with 40°C UT and sufficient ventilation						
S 1 – 0,022	0,022	122	150	183	211	250	344	M10
S 2 – 0,027	0,027	122	150	183	211	250	344	M10
S 3 – 0,033	0,033	122	150	183	211	250	344	M10
S 4 – 0,039	0,039	112	138	168	194	230	315	M10
S 5 – 0,047	0,047	102	126	153	177	210	287	M10
S 6 – 0,056	0,056	94	115	140	163	193	265	M10
S 7 – 0,068	0,068	85	105	127	147	174	240	M10
S 8 – 0,082	0,082	77	96	115	133	158	217	M10
S 9 – 0,10	0,10	70	87	105	121	144	197	M10
S 10 – 0,12	0,12	64	79	96	111	131	180	M10
S 11 – 0,15	0,15	57	71	85	99	117	160	M6
S 12 – 0,18	0,18	52	65	78	90	107	146	M6
S 13 – 0,22	0,22	47	58	71	81	96	132	M6
S 14 – 0,27	0,27	42	53	63	73	86	118	M6
S 15 – 0,33	0,33	38	48	58	68	79	108	M6
S 16 – 0,39	0,39	35	44	53	62	73	100	M6
S 17 – 0,47	0,47	32	40	48	55	65	90	M6
S 18 – 0,56	0,56	29	37	44	51	60	83	M6
S 19 – 0,68	0,68	27	33	41	47	55	76	M6
S 20 – 0,82	0,82	24	30	36	42	49	67	M6
S 21 – 1,0	1,0	22	27	33	38	45	62	M6
S 22 – 1,2	1,2	20	25	30	35	41	56	M6
S 23 – 1,5	1,5	18	22,5	27	31	37	51	M6
S 24 – 1,8	1,8	16,5	20,5	25	28	34	46	M6
S 25 – 2,2	2,2	15	18,5	23	26	31	42	M6
S 26 – 2,7	2,7	13,5	16,5	20	23	27	37	M6
S 27 – 3,3	3,3	12	15	18	21	25	34	M6
S 28 – 3,9	3,9	11	14	16	19	23	31	M6
S 29 – 4,7	4,7	10	12,5	15	18	21	28	M6
S 30 – 5,6	5,6	9,3	11,3	13,7	16	18,6	25	M6

^① only valid for S3 – S30

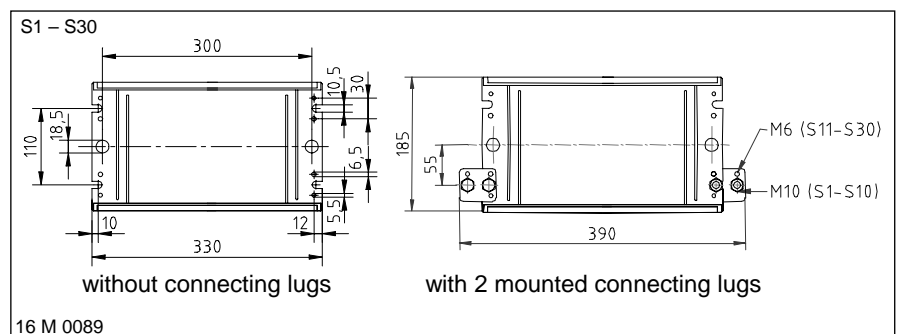

16 M 0089



Type series FE 31..

1,0 – 22 kW for integration

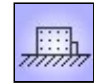

Steel-grid fixed resistor block, degree of protection IP 00 for integration into switch cabinets, units or ventilation ducts. Connection directly at the resistor.

② optional, type designation would be FE.U 31..

Technologies

- for smaller up to middle power rating
• integration and combinations possible
• for mounting into switch cabinet, resistor unit or ventilation duct
• continuous power rating up to 22 kW
• optional with temperature switch (TS), with fast-on connectors 6,3x0,8; type designation would be FEQ 31...,

Each resistor block can be equipped with 2 or several connecting lugs Depending on the current the connection is realized by M6 or M10 screw. The mounting into the switch cabinet, resistor unit or ventilation duct is made by M12 thread bolts.

By means of series connection of steel-grid elements we achieve higher ohmic values; by connecting in parallel several resistor blocks we achieve higher currents and power ratings.

We can also mount several partial resistors on one resistor block (e.g. 3 phases), divided by insulation rolls.

Warning:

Not more than 3 resistor blocks should be mounted on top of each other!

Application

An important application is the use as load resistor, where high power rating is demanded by the user.

Further applications are e.g. the mounting of the steel-grid blocks into a ventilation duct with simultaneous forced ventilation by the exhaust air of a diesel engine radiator.

Electrical and mechanical data

Table with 6 columns: type, typical power in kW at 40°C and 100% DCF, production range Ω-value (from/to), number of steel-grids corresp. to given device size, dimensions in mm (L), max. weight in kg. Rows include types FE. 31503.. to FE. 31444..

This table represents only a selection of our program. All numbers of steel-grids between 2 pc. (1,0 kW) und 44 pc. (22 kW) corresponding to our types are available. Type code and selection of units see Technical Details pages T613E to T619E.

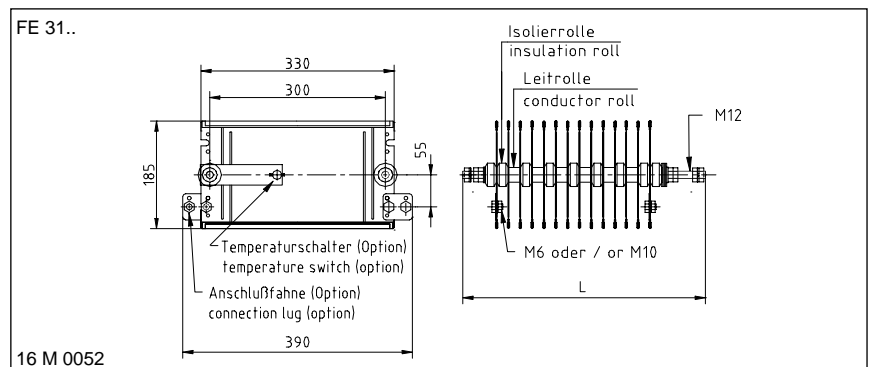

Example of dimensioning and selection of a special unit:

One phase load resistor: 5,0 kW for 48 V DC; resistance value 0,46 Ω; selected: 9 S5 -0,047 +1 S4-0,039 Ω = 0,46 Ω; type FE 3111002 - 0,46 with typical power 5,0kW, connection on 2 connection lugs M10 at the resistor, with temperature switch (2 connections)

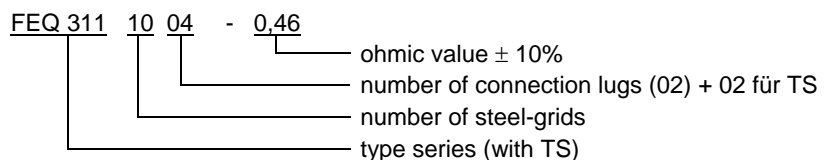



Type series FKE 31..

1,0 – 22 kW for integration

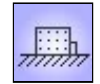

Steel-grid fixed resistor, degree of protection IP 00, with side plates for integration into a switch cabinet. Connection directly at the resistor.

② optional, the type designation would be FKE.U 31..

Technologies

- especially compact construction form, dimensions depend on number of installed steel-grids.
- small to middle power rating
- continuous power rating up to 22 kW
- integration into switch cabinet possible
- temperature switch optional (TS), with fast-on connectors 6,3x0,8; type designation would be FKEQ 31...

Each resistor can be delivered with 2 or several connection lugs. Depending on the current the lugs are equipped with M6 or M10 screws. The resistor is mounted in a cabinet by means of the two side plates.

Mounting of several partial resistors (e.g. 3-phases) into one resistor unit is possible. They are separated by insulation rolls.

You will find suggestions for the dimensioning of the resistor for short time load in chapter "Technical Details", pages T613E to T619E.

Application

Customized solutions like integrating a resistor unit into a switch cabinet, when a very compact construction form is needed.

Thus various kinds of solutions are possible for many applications such as:

- load resistors
- charging or discharging resistors
- braking resistors
- starting and regulating resistors etc.
- damping resistors

Electrical and mechanical data

type FKE 3.. without TS, FKEQ 3.. with TS	typical power in kW at 40°C and 100%DCF	production range Ω-value		number of steel-grids corresp. to given device size	dimensions in mm		max. weight in kg
		from	to		A	B	
FKE. 31503..	1,5	0,07	16	3	147	162	4,4
FKE. 31504..	2,0	0,09	22	4	167	182	5,0
FKE. 31005..	2,5	0,11	28	5	187	202	5,6
FKE. 31007..	3,5	0,15	39	7	227	242	6,8
FKE. 31009..	4,5	0,20	50	9	267	282	7,9
FKE. 31112..	6,0	0,26	67	12	327	342	9,7
FKE. 31114..	7,0	0,31	78	14	367	382	10,8
FKE. 31216..	8,0	0,35	89	16	407	423	12,0
FKE. 31220..	10,0	0,44	112	20	487	503	14,3
FKE. 31224..	12,0	0,53	134	24	567	583	16,6
FKE. 31326..	13,0	0,57	145	26	607	623	17,8
FKE. 31330..	15,0	0,66	168	30	687	703	20,1
FKE. 31334..	17,0	0,75	190	34	767	783	22,4
FKE. 31436..	18,0	0,79	201	36	807	823	23,6
FKE. 31440..	20,0	0,88	224	40	887	903	25,9
FKE. 31444..	22,0	0,97	246	44	967	983	28,2

This table represents only a selection of our program. All numbers of steel-grids between 2 pc. (1,0 kW) und 44 pc. (22 kW) corresponding to our types are available. Type code and selection of units see Technical Details pages T613E to T619E

The dimensions A and B increase by 20 mm per each steel-grid element (SG)

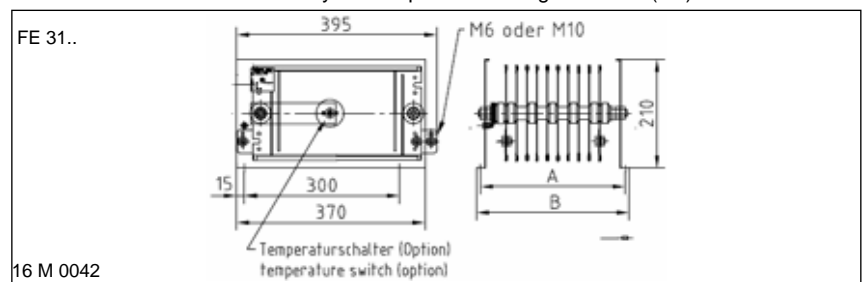

16 M 0042

Example of dimensioning and selection of a specific unit:

Three phase load resistor: for 3 x 3,0 kW = 9,0 kW for 3 x 230/400 V; 50 Hz, 3 x 13 A, 3 x 17,7 Ω, starpoint on connection lug:
selected: 5 S26 – 2,7 Ω + 2 S25 – 2,2 Ω = 17,9 Ω; 3 x 7 SG
type FKE 3122104 – 3 x 17,7 with typical power 3 x 3,0 kW, connection on 4 connection lugs at the resistor

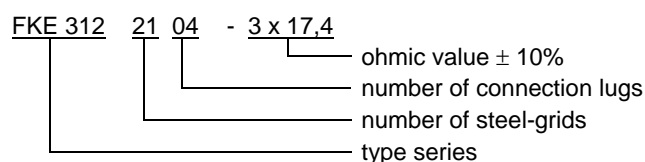



Type series FGF.. 31..

1,0 – 22 kW with 2 terminals



Steel-grid fixed resistor unit, degree of protection IP 20 if mounted on an appropriate surface, with zinc plated steel enclosure. It is equipped with max. 2 terminals of different kinds mounted in or at the enclosure or in the attached terminal box. Some types can be provided with a temperature switch or with an integrated thermal overload relay. For your selection of a specific type you will find tables on the next page.

① if mounted on an appropriate surface

② optional, type designation would be FGF..U 31..

Technologies

- low priced type, very compact design
- continuous power rating up to 22 kW
- for mounting on top of a switch cabinet (all types besides FGFD..)
- for integration into a switch cabinet with terminals that are protected against contact (type FGFD..)
- units may be wall or plate mounted, perforated steel sheet at the front, top and bottom, terminals at the bottom.
- terminal type and size selectable according to mounting place and connection technics
- optional with temperature switch (type FGF.Q)
- optional with thermal overload relay (type FGFT)

Application

These units are fitting especially for mounting on, beside or in a switch cabinet by their relatively flat and compact construction in 6 widths with various connections and monitoring possibilities (Please mind the description of the types).

An important application is the use as braking resistor for motor/generator drive of motors with frequency converters, where high power rating is combined with low budget solution.

You will find suggestions for the dimensioning of the resistor for short time load at chapter Technical Details, pages T613E to T619E.

Warning

When resistor is integrated into a cabinet we recommend to provide a corresponding forced ventilation by the user for better removal of larger dissipations.

Details of the different types

Type FGFG:

Construction with 2 flat terminals up to max. 35 A rated current in the attached terminal box with cable gland. Additional temperature switch is not available.

Type FGFK(Q):

Construction see FGFG, but with larger terminal box with cable gland and room for 2 terminals up to M8 (max.115 A rated current) and for 2 additional porcelain terminals for optional temperature switch (FGFKQ).

Type FGFL(Q):

Construction, where all the terminals up to M8 (max. 115 A rated current) are mounted on a terminal strip inside the unit. You can reach the terminals if part of the cover is removed. If equipped with temperature switch there are 2 additional porcelain terminals inside the unit (FGFLQ).

Type FGFD(Q):

Construction with feed-through terminals up to max. 65 A that are protected against contact and directly fixed on the mounting plate. It is a space-saving solution for integrating into a switch cabinet. If equipped with temperature switch there are 2 additional protected feed-through terminals (FGFDQ).

Type FGFT:

Construction with integrated thermal overload relay in the attached terminal box with cable gland up to max. 80 A rated current plus integrated short-circuit and overload alarm. Connection directly on the overload relay.

Rated current and cross sections of terminals

type	abbreviation	rated current in A up to		max cross section
		100%ED	40%ED	
porcelain terminal	PK	16		up to 2,5 mm ²
ceramic flat terminal	FK	35	44	2,5 - 10 mm ²
device terminal out of polyamid (PA)	G 5	30	38	0,5 – 2,5 (4) mm ² AWG 24 - 12
	G 10	60	75	0,5 – 10 (16) mm ² AWG 20 - 6
ceramic bolt terminal	BK M6	60	75	cross section depending on lug size with corresponding hole
	BK M8	115	143	
PA feed-through terminal	HDFK4	30	38	up to 4,0 mm ² ; AWG 24 - 12
	HDFK10-HV	65	82	up to 10 mm ² ; AWG 20 - 6
PA cage clamp terminal	ST2,5	20	25	up to 2,5 mm ² ; AWG 26- 12
	ST4	30	38	up to 4,0 mm ² ; AWG 20-10



Type series FGF.. 31..

1,0 – 22 kW with 2 terminals

Options:

Temperature switch (..Q)

For temperature monitoring we provide certain types with a 85° C temperature switch to announce an overloading of the resistor by a normally closed contact free of potential. This warning should be followed by actions of the user, e.g. by an alarm or switching of the circuit from the mains.

Warning: There will not be a disconnection of the resistor!

Connection

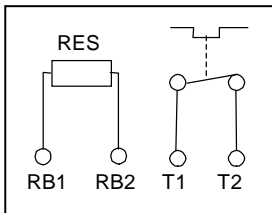

Thermal overload relay (..T)

A possible overloading of the resistor is signalled by a thermal overload relay mounted in the attached terminal box. This warning should be followed by actions of the user, e.g. by an alarm or switching of the circuit from the mains.

Warning: There will not be a disconnection of the resistor!

cross sections:

fine stranded, for relays up to	cross section in mm ²		
	17A	32A	80 A
main current	1 x 2,5	2 x 4	1 x 25
auxiliary curr.	1 x 2,5	1 x 2,5	1 x 2,5

Connection:

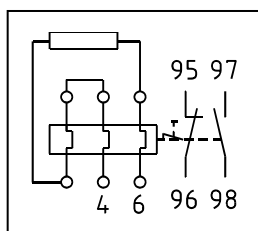

Contact rating

Contact rating of the alarm contacts of temperature switches and overload relays:

- 2 A / 24 VDC (DC11)
- 2 A / 230 VAC (AC11)

Decision matrix

Type	FGFG	FGFK	FGFKQ	FGFL	FGFLQ	FGFD	FGFDQ	FGFT
properties								
with temperature switch (TS)			X		X		X	
thermal overload relay (up to max. 80 A rated current)								X
terminals in attached terminal box with PG- strain relief	X	X	X					X
terminals inside unit (without PG- strain relief)				X	X			
flat terminals up to max. 35 A	X	X	X	X	X			
device terminal up to max. 60 A		X	X					
bolt terminals M6 up to max. 60 A		X	X	X	X			
bolt terminals M8 up to max. 115 A		X	X	X	X			
feed-thru terminals up to max. 65 A						X	X	
PA cage clamp terminals up to max. 30 A		X	X					

Electrical and mechanical data

types FGFG, FGFK, FGFKQ, FGFL, FGFLQ, FGFD, FGFDQ, FGFT	typical power in kW at 40°C and 100% DCF	production range Ω-value		number of steel-grids corresp. to given device size	dimensions in mm					max. weight in kg
		from	to		A	B	C1 ①	C2 ②	C3 ③	
FGF.. 31503..	1,5	0,07	16	3	170	195	207	230	255	6,0
FGF.. 31504..	2,0	0,09	22	4	170	195	207	230	255	6,5
FGF.. 31005..	2,5	0,11	28	5	270	295	307	330	355	7,5
FGF.. 31007..	3,5	0,15	39	7	270	295	307	330	355	8,5
FGF.. 31009..	4,5	0,20	50	9	270	295	307	330	355	9,5
FGF.. 31112..	6,0	0,26	67	12	370	395	407	430	455	12
FGF.. 31114..	7,0	0,31	78	14	370	395	407	430	455	13
FGF.. 31216..	8,0	0,35	89	16	570	595	607	630	655	18
FGF.. 31220..	10,0	0,44	112	20	570	595	607	630	655	20
FGF.. 31224..	12,0	0,53	134	24	570	595	607	630	655	22
FGF.. 31326..	13,0	0,57	145	26	770	795	807	830	855	29
FGF.. 31330..	15,0	0,66	168	30	770	795	807	830	855	31
FGF.. 31334..	17,0	0,75	190	34	770	795	807	830	855	33
FGF.. 31436..	18,0	0,79	201	36	970	995	1007	1030	1055	40
FGF.. 31440..	20,0	0,88	224	40	970	995	1007	1030	1055	42
FGF.. 31444..	22,0	0,97	246	44	970	995	1007	1030	1055	44

This table represents only a selection of our program. All numbers of steel-grids between 2 pc. (1,0 kW) und 44 pc. (22 kW) corresponding to our types are available. Type code and selection of units see Technical Details pages T613E to T619E

Example: 2 device terminals + temperature switch (2 terminals) => FGFKQ 31...04

- ① dim. C1 is only valid for Type FGFD (dimension sheet 16M0442)
- ② dim. C2 is only valid for Type FGFG (dimension sheet 16M0041)
- ③ dim. C3 valid for types FGFK (dim. sheet 16M0041), FGFT (dim. sheet 16M0086) for type FGFL dim. „B“ is valid, as design without term.box (dim. sheet 16M0424)

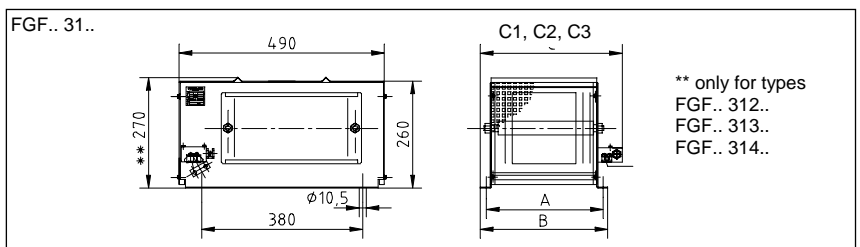



Type series FGHD 31..

1,0 – 12 kW with 2 terminals, for integration into switch cabinet

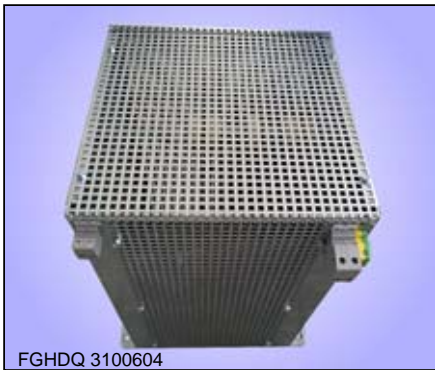

Steel-grid fixed resistor, degree of protection IP 20 in fixed condition, in zinc plated steel sheet enclosure with 2 feed-through terminals for the resistor, that are integrated into the side-panel end plates, protected against contact according to BGV A2. Optional also with temperature switch (TS).

① if mounted on an appropriate surface

② optional, type designation would be FGHD.U 31..

Technologies

- low priced type, very compact design
- for middle power ratings up to 12 kW
- for space saving integration into a switch cabinet
- optional with temperature switch wired on two terminals. Type designation would be FGHDQ. 31...

The given power rating values are valid for 100%CD (continuous dissipation). For short time operation you will find the values in the following table as a function of the duty cycle factor (DCF). Just multiply by the corresponding overload factor (OLF).

DCF	60%	40%	25%	15%	6%
OLF	1,5	2,2	3,0	4,0	7,6

These overload factors are valid for a total cycle time of maximum 120 s

You will find further details in chapter Technical Details pages T613E to T619E.

Application

An important application is the use as braking resistor for motor/generator drive of motors with frequency converters, where middle power ratings are to be integrated into a switch cabinet in a space saving way.

Warning

The user has to make sure that large dissipations are removed. We recommend an adequate forced ventilation.

Electrical and mechanical data

Type FGHD. 31.. without TS, FGHDQ. 31.. with TS	typical power in kW at 40°C and 100% DCF	production range Ω-value		max. number of steel-grids corresp. to given device size	dimensions in mm		max. weight in kg
		from	to		A	B	
FGHD..31502..	1,0	0,05	11	2	170	195	6,0
FGHD..31503..	1,5	0,07	16	3	170	195	6,5
FGHD..31504..	2,0	0,09	22	4	170	195	7,0
FGHD..31005..	2,5	0,11	28	5	270	295	7,5
FGHD..31007..	3,5	0,15	39	7	270	295	8,5
FGHD..31009..	4,5	0,20	50	9	270	295	9,5
FGHD..31112..	6,0	0,26	67	12	370	395	12
FGHD..31114..	7,0	0,31	78	14	370	395	13
FGHD..31216..	8,0	0,35	89	16	570	595	18
FGHD..31220..	10,0	0,44	112	20	570	595	20
FGHD..31224..	12,0	0,53	134	24	570	595	22

This table represents only a selection of our programm. All numbers of steel-grids corresponding to our types between 2 pc. (1,0 kW) und 24 pc. (12 kW) are available. Type code and selection of units see Technical Details pages T613E to T619E

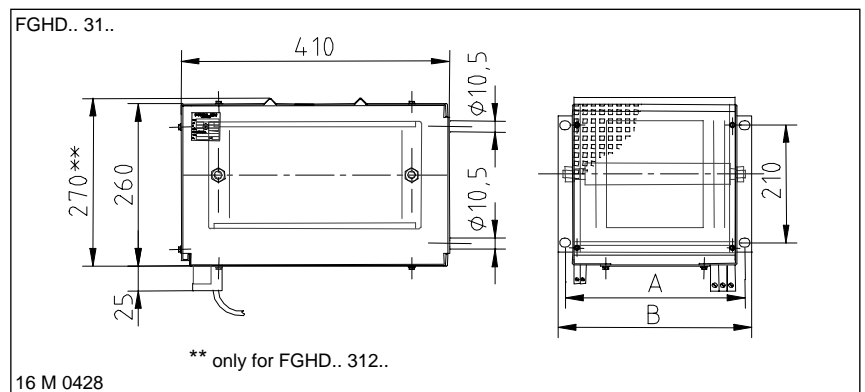

Example of dimensioning and selection of a specific unit:

One phase braking resistor for frequency converter drive with temperature switch, short time dissipation 24 kW at 15% DCF, total cycle time shorter than 120 s, intermediate voltage circuit 650V; resistance value 18 Ω; calculating of continuous dissipation: 24 kW : 4,0 = 6,0 kW; chosen: FGHD 3111204 - 18

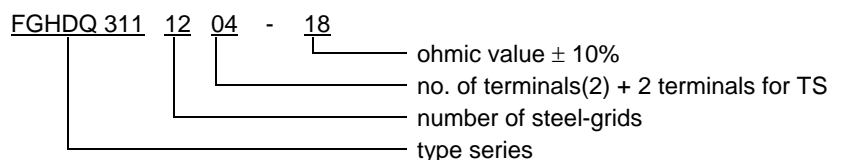



Type series FK 3..

1,5 – 66 kW with up to 40 terminals



Steel-grid fixed resistor unit, degree of protection IP 00 with 2 side-panel end plates out of zinc plated steel sheet. Ceramic isolated flat or bolt terminals of 35 A up to 400 A in variable combinations available.

② optional, type designation would be FK.U 3..

Technologies

- for middle and high power ratings
- Up to 40 FK-terminals
- continuous dissipation up to 66 kW
- for floor-level mounting
- optional with temperature switch (TS), type designation would be then FKQ 3...

The necessary terminals are mounted on a terminal strip in the lower part of the device.

You will find suggestions for the dimensioning of the resistor for short time load at chapter Technical Details, pages T613E to T619E.

Application

This construction is especially appropriate for big power ratings that are to be low in weight and in price. The same applies to the integration or to the use in closed electronical rooms, where degree of protection IP 00 is allowed.

Special design

- dimensioning for forced ventilation supplied by the user
- special construction forms for integration into exhaust air ducts for engine radiators

Option

- with temperature switch wired on 2 terminals, type then FKQ...

Electrical and mechanical data

Type FK 3.. without TS, FKQ 3.. with TS	max. typical power in kW at 40°C and 100% DCF	production range Ω-value		max. number of steel-grids corresp. to given type size	dimensions in mm			max. weight in kg
		from	to		A	B	C	
FK. 31114..	7,0	0,31	78	14	370	395	460	19
FK. 31224..	12,0	0,53	134	24	570	595	460	26
FK. 31334..	17,0	0,75	190	34	770	795	460	38
FK. 31444..	22,0	0,97	246	44	970	995	460	45
FK. 32128..	14,0	0,16	156	28	370	395	710	31
FK. 32248..	24,0	0,27	268	48	570	595	710	46
FK. 32368..	34,0	0,38	380	68	770	795	710	70
FK. 32488..	44,0	0,49	492	88	970	995	710	80
FK. 33272..	36,0	0,18	403	72	570	595	960	62
FK. 33302..	51,0	0,25	570	102	770	795	960	87
FK. 33432..	66,0	0,32	739	132	970	995	960	115

This table only represents the maximum number of steel-grids of the specific size of unit and the corresponding maximum typical power. All numbers of steel-grids corresponding to our types between 3 pc. (1,5 kW) und 132 pc. (66 kW) are available. Type code and selection of units see Technical Details pages T613E to T619E

Type	Max. number of terminals up to					
	FK 35A	BK M6 60A	BK M8 115A	BK M10 170A	BK M10 220A	BK M12 400A
FK. 3.1..	16	10	8	7	7	7
FK. 3.2..	24	16	14	12	12	11
FK. 3.3..	32	23	20	17	17	16
FK. 3.4..	40	30	26	22	22	20

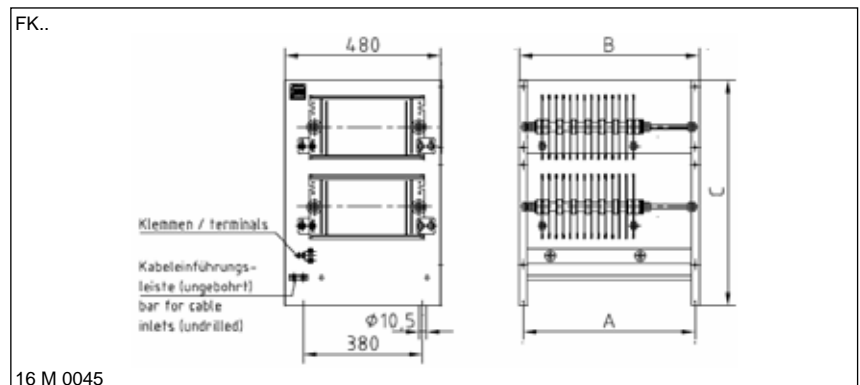

Example of dimensioning and selection of a specific unit:

see Technical Details pages T613E to T619E



Type series FKK.. 3..

5,0 – 250 kW, in duct design

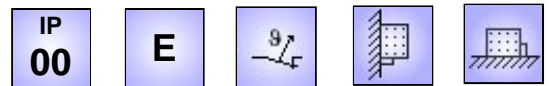

Steel-grid fixed resistor unit, degree of protection IP 00 integrated in a duct section for integration by the user into existing or new exhaust air installations, in a zinc steel sheet duct with attached terminal box and optional temperature switch.

Technologies

- for middle or high power ratings
- low priced solution for existing forced ventilation provided by the customer
- continuous dissipation up to 250 kW
- prepared for integration into customer's duct.
- For exhaust air temperatures up to 60°C
- optional with temperature switch wired on two terminals, type designation would be FKKEQ 3...

We provide ceramic insulated flat or bolt terminals of 35 A up to 400 A and mount the required terminals into an attached terminal box.

On behalf of a large range of dimensions, vertically as well as horizontally, we realize all kinds of duct cross sections.

Application

An important application is the use as load resistor for emergency power units

For cases where an installation is to be protected by a base load against "wear" due to small load or when necessary or compulsory load testings of the efficiency must be accomplished.

We are specialists in customized solutions!

Special designs

- integration into ducts, provided by the customer, type series FKKF..
- integration kit for integration by the user
- in 5-tiers construction
- with integration of 2 resistor sets in a row
- with wind indicator monitoring

Electrical and mechanical data

Type FKK. 3.. without TS, FKKEQ. 3.. with TS	max. typical power in kW at 40°C and 100% DCF	max. number of steel-grids corresp. to given device combination (n x m)	dimensions in mm						max. weight in kg
			max. block # (n)	duct height		duct width			
A	B	max. SG-# (m)		C	D				
F.. 31215..	15,0	15	1	415	475	15	415	475	25
F.. 32236..	37,5	36	2	450	510	18	450	510	35
F.. 32242..	45,0	42	2	550	610	21	500	560	47
F.. 32248..	50,0	48	2	600	660	24	550	610	50
F.. 32354..	60,0	54	2	650	710	27	630	690	55
F.. 33384..	95,0	84	3	690	750	28	650	710	85
F.. 33390..	100	90	3	720	780	30	700	760	88
F.. 33399..	112,5	99	3	750	810	33	765	825	95
F.. 34444..	160	144	4	900	960	36	810	870	135
F.. 34460..	180	162	4	1000	1060	41	900	960	150

This table represents only a selection of what can be combined concerning duct dimensions. Other combinations and other dimensions are available, of course. All numbers of steel-grids corresponding to our types between 12/18 pc. (5 kW) und 264 pc. (250 kW) are available. Type code and selection of units see Technical Details pages T613E to T619E Please let us know your specific case of application. We will exactly meet your requirements.

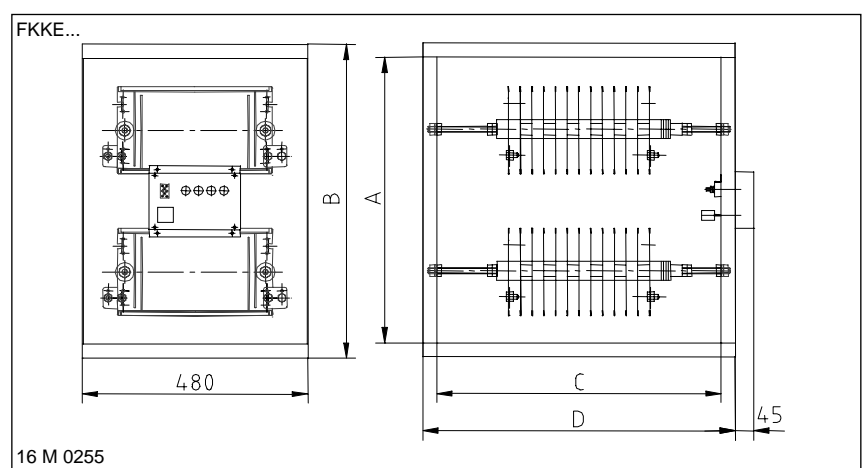

Example of dimensioning and selection of a specific unit:

Please contact us, we will be glad to work on a detailed offer for you!



Type series FA 3.. / FS 3..

1,5 – 66 kW with several terminals



FA... Steel-grid fixed resistor unit, degree of protection IP 20 without weatherproof roof,

FS... Steel-grid fixed resistor unit, degree of protection IP 23 with weatherproof roof

In completely closed zinc sheet enclosure with stationary safety guard at the top and bottom. Ceramic insulated flat or bolt terminals of 35 A up to 400 A in variable combinations available.

② optional, the type designation would be FA.U 3.. / FS.U 3..

Technologies

- for middle and high power ratings
- Up to 40 FK-terminals
- continuous dissipation up to 66 kW
- for floor-level mounting
- for outdoor location (FS...)
- optional with temperature switch (TS) wired on two terminals, the type designation would be F.Q. 3...

The necessary terminals are mounted on a terminal strip in the lower part of the device and are accessible after demounting a cover.

By the use of 12 different enclosure sizes – with 3 heights and 4 widths we can well adapt the construction form to the given space. In the range between 14 and 88 steel-grids you can make your choice between smaller and lower forms.

You will find suggestions for the dimensioning of the resistor for short time load at chapter Technical Details, pages T613E to T619E.

Application

An important application is the use as braking resistor for motor/generator drive of motors with frequency converters, where big power ratings are necessary for outdoor location combined with degree of protection IP 20 or IP 23.

Special design

- For special applications also in a four-tier design
- Enclosure additionally varnished in RAL 7032 or other colours
- Connection parts and enclosure out of stainless steel 1.4301

Electrical and mechanical data

Type FA 3.. / FS 3.. without, FAQ 3.. / FSQ 3.. with TS	max. typical power in kW at 40°C and 100% DCF	production range Ω-value		max. number of steel-grids corresp. to given device size	dimensions in mm				max. weight in kg
		from	to		A	B	C	D only IP23	
F.. 31114..	7,0	0,31	78	14	370	395	460	520	26
F.. 31224..	12,0	0,53	134	24	570	595	460	520	36
F.. 31334..	17,0	0,75	190	34	770	795	460	520	51
F.. 31444..	22,0	0,97	246	44	970	995	460	520	61
F.. 32128..	14,0	0,16	156	28	370	395	710	770	41
F.. 32248..	24,0	0,27	268	48	570	595	710	770	61
F.. 32368..	34,0	0,38	380	68	770	795	710	770	86
F.. 32488..	44,0	0,49	492	88	970	995	710	770	101
F.. 33272..	36,0	0,18	403	72	570	595	960	1100	82
F.. 33302..	51,0	0,25	570	102	770	795	960	1100	112
F.. 33432..	66,0	0,32	739	132	970	995	960	1100	138

This table only represents the maximum number of steel-grids of the specific size of unit and the corresponding maximum typical power. All numbers of steel-grids corresponding to our types between 3 pc. (1,5 kW) und 132 pc. (66 kW) are available. Type code and selection of units see Technical Details pages T613E to T619E.

Type	Max. number of terminals up to					
	FK 35A	BK M6 60A	BK M8 115A	BK M10 170A	BK M10 220A	BK M12 400A
F.. 3.1..	16	10	8	7	7	7
F.. 3.2..	24	16	14	12	12	11
F.. 3.3..	32	23	20	17	17	16
F.. 3.4..	40	30	26	22	22	20

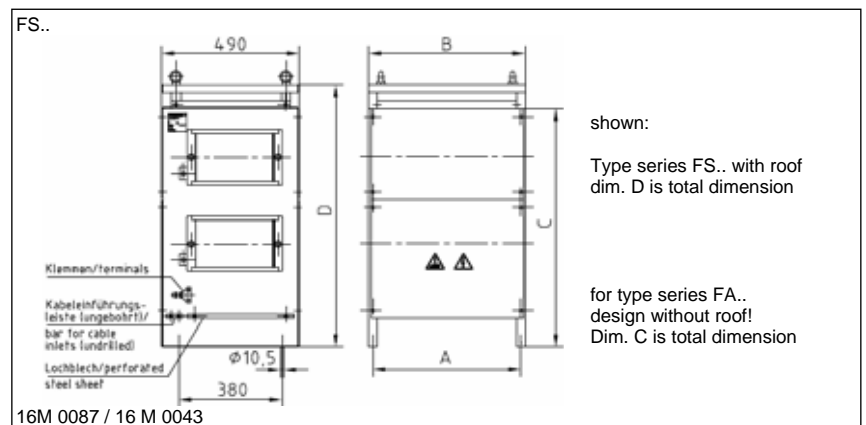

Example of dimensioning and selection of a specific unit:

see Technical Details pages T613E to T619E



Type series FS 319.. / FS 320..

0,5 – 5,0 kW with 2 terminals



Steel-grid fixed resistor unit, degree of protection IP 23 with weatherproof roof, appropriate for outdoor mounting, in zinc steel sheet enclosure for connection with 2 terminals, with several drills for cable lead-throughs that are closed by rubber sockets.

Technologies

- for smaller power ratings
- compact construction form
- continuous dissipation up to 5,0 kW
- units may be wall mounted , horizontal mounting not admitted
- for outdoor mounting (FS...)

The necessary terminals are mounted in the lower part of the device and are accessible after demounting the cover. We can mount 2 flat or 2 bolt terminals M6 or M8.

You will find suggestions for the dimensioning of the resistor for short time load at chapter Technical Details, pages T613E to T619E.

Application

On behalf of small dimensions and compact construction form this type series is especially appropriate as load resistor for small power ratings, if degree of protection IP 23 is necessary.

A lot of applications are possible because of the high degree of protection and the wall mounting, such as the outdoor mounting.

Special design

- degree of protection IP 20 (without roof), type FA 319.. / FA 320..

Electrical and mechanical data

type	max. typical power in kW at 40°C and 100% DCF	production range Ω -value		max. number of steel-grids corresp. to given device size	dim. in mm F	drills for cable lead-throughs M	max. weight in kg
		from	to				
FS 3190602	3,0	0,11	33,6	6	200	1 x PG 13,5 + 1 x PG 16	9,5
FS 3201002	5,0	0,22	56,0	10	335	+ 3 x PG21	12

This table only represents the maximum number of steel-grids of the specific size of unit and the corresponding maximum typical power. All numbers of steel-grids corresponding to our types between 1pc. (0,5 kW) and 10 pc. (5,0 kW) are available.

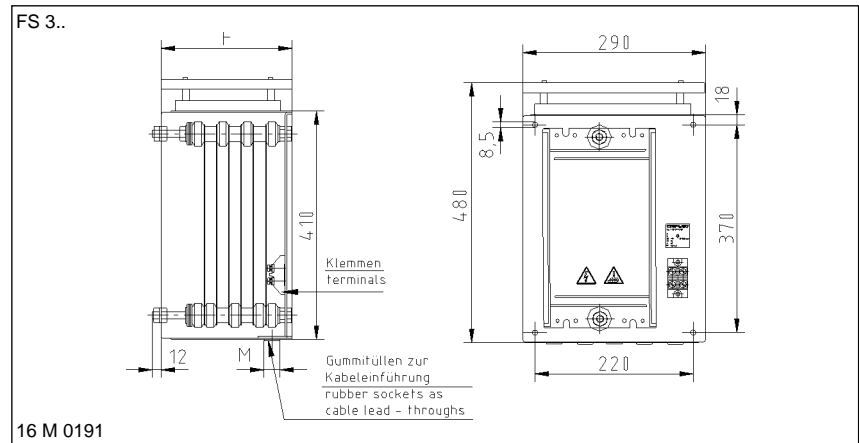

Example of dimensioning and selection of a specific unit:

One phase starting resistor as constant series resistor for motor 220 V DC; 8,5 kW, 51 A; resistor value 0,72 Ω ; continuous dissipation approx. 1,9 kW; chosen: FS 3190402 – 0,72 with continuous dissipation 2 kW; this corresponds to 4 steel-grids S12 - 0,18 Ω = 0,72 Ω , connection with 2 bolt terminals M6

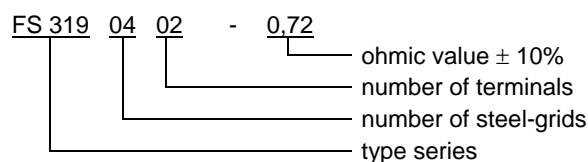



Type series FAV 3../FSV 3..

70 – 250 kW with several terminals



FAV... Steel-grid fixed resistor unit, degree of protection IP 20, without weatherproof roof, air outlet on top,

FSV... Steel-grid fixed resistor unit, degree of protection IP 23 with weatherproof roof, for outdoor location, air outlet at the side via air deflectors in the upper area.

In completely closed zinc sheet enclosure with barrier grid at the bottom and powered ventilation by an integrated ventilator. With air flow monitoring by wind indicator relay. Ceramic insulated flat or bolt terminals of 35A up to 400A in variable combinations available.

Technologies

- for high power ratings
- power ventilated by integrated 230/400 V; 50 Hz axial flow fan
- for floor-level location
- continuous dissipation up to 250 kW
- paralleling of 2 or more units for even higher powers
- for outdoor location (FS...)

The necessary terminals are mounted on a terminal strip in the lower part of the device and are accessible after demounting a cover.

By the use of steel-grid elements with a typical power of 1100 W per steel-grid with forced ventilation we cover a power range of up to 250 kW per unit. Higher power ratings can be achieved by parallel connection of several devices.

Application

An important application is the use as load resistor for the testing of emergency power installations. For location in operating rooms the degree of protection IP 20 is necessary and for outdoor location degree of protection IP 23.

Special design

- with integrated switching devices in an attached switch cabinet for controlling the partial resistors
- with 2 temperature switches wired on terminals.
- special voltages for flow fan
- please ask for devices with higher power ratings or other construction forms
- mobile

Electrical and mechanical data

type FAV 3.. FSV 3..	max. typical power in kW at 40°C and 100% DCF	max. number of steel-grids corresp. to given size of device	dimensions in mm						max. weight in kg
			A	B	C	D	E	F	
F.V 38568..	75	68	1200	1240	800	700	795	770	142
F.V 38602..	110	102	1500	1540	800	700	795	770	185
F.V 38776..	185	176	1400	1450	955	850	995	970	265
F.V 38864..	250	264	1700	1750	955	850	995	970	370

This table represents only the maximum number of steel-grids of the specific size of unit and the corresponding maximum typical power. Many specifications depending on customer requirement are possible.

Standard load resistors for 3 x 230/400 V; 50 Hz

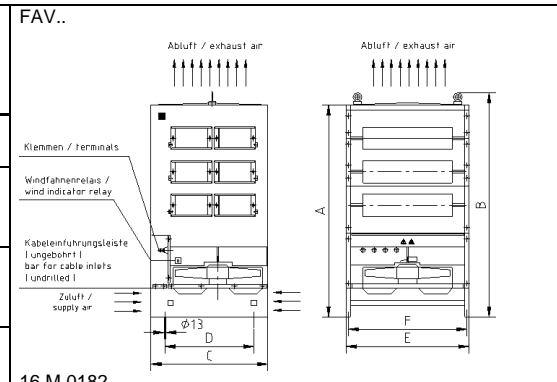
type FAV..	partial resistors in kW	FAV.. 
FAV 3856609	75	16 M 0182
FAV 3856612	37,5/37,5	
FAV 3869609	100	
FAV 3869612	50/50	
FAV 3860218	10/20/20/50	
FAV 3876809	175	
FAV 3876812	75/100	
FAV 3876818	50/50/50/25	
FAV 3884009	250	
FAV 3884012	150/100	
FAV 3884021	5 x 50	

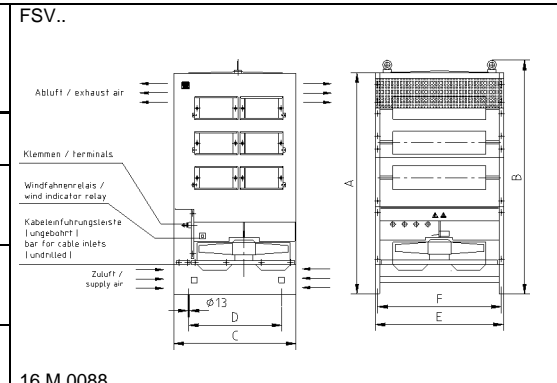
type FSV..	partial resistors in kW	FSV.. 
FSV 3856609	75	16 M 0088
FSV 3856612	37,5/37,5	
FSV 3869609	100	
FSV 3869612	50/50	
FSV 3860218	10/20/20/50	
FSV 3876809	175	
FSV 3876812	75/100	
FSV 3876818	50/50/50/25	
FSV 3884009	250	
FSV 3884012	150/100	
FSV 3884021	5 x 50	