

MS 640

Programmable Motion Monitor for Secure and Redundant Control of Motion Sequences



- Suitable for monitoring of overspeed, underspeed, standstill, direction of rotation, slip, shaft or gearbox fracture, impermissible motion etc.
- Six logical inputs for plausibility considerations and control of logical conditions
- Two programmable inputs for quadrature encoders (each A, /A, B, /B for counting frequencies up to 500 kHz)
- Four safety relays with forced-guided contacts and four high-speed transistor outputs, all with feedback and control of the actual output state
- Serial RS232 and RS485 interfaces for remote access to all functions and data
- High safety level on the machine site by redundant and logical control algorithms
- High functional safety of the monitor itself by internal test routines and diagnostics

Operating Instructions



Safety Instructions

- This manual is an essential part of the unit and contains important hints about function, correct handling and commissioning. Non-observance can result in damage to the unit or the machine or even in injury to persons using the equipment!
- The unit must only be installed, connected and activated by a qualified electrician
- It is a must to observe all general and also all country-specific and application-specific safety standards
- When this unit is used with applications where failure or maloperation could cause damage to a machine or hazard to the operating staff, it is indispensable to meet effective precautions in order to avoid such consequences
- Regarding installation, wiring, environmental conditions, screening of cables and earthing, you must follow the general standards of industrial automation industry
- - Errors and omissions excepted –



General instructions for cabling, screening and grounding can be found in the SUPPORT section of our website <http://www.motrona.com>

Version:	Description:
MS64001a/mb/hk_05/2010	Preliminary version
MS64001b/pp_12/2011	Inserted new picture
MS64001c/mb/nw_02/2013	Adjustment of the ambient temperature
MS64002a/mb/nw_04/2013	Extension of Parameter F10.146 "Start Display"

Table of Contents

1.	Introduction and Application	4
2.	Electrical Connections	5
2.1.	Connection Diagram	5
2.2.	Terminal Assignments	6
2.3.	Power Supply	7
2.4.	Auxiliary Outputs for Encoder Supply	7
2.5.	Impulse Inputs for Incremental Encoders	8
2.6.	Control Inputs 1 – 4	9
2.7.	Logical Inputs Login1 - 6	9
2.8.	High Speed Transistor Outputs Out 1n - Out 4n (n = normal) and Out 1s - Out 4s (s = safe)	9
2.9.	Forced-Guided Safety Relays Rel.1s - Rel.4s	10
2.10.	Serial Interface	11
3.	Relevant Process Data and Setpoints	12
3.1.	Available Actual Values	12
3.2.	Available Setpoints	13
3.3.	Available Criteria for Combination of Switching Events	13
3.4.	Generation of an Output Signal	15
3.5.	Indication of Switching Functions	16
3.6.	Operation of the Status Signals	16
4.	Setup of the Unit by PC	17
4.1.	PC connection	17
4.2.	The Main Screen	17
4.3.	PC Screen for Configuration of Switching Functions	19
5.	Keypad Operation	21
5.1.	Normal Operation	21
5.2.	General Setup Procedure	21
5.3.	Change of Parameter Values on the Numeric Level	23
5.4.	Code Protection against Unauthorized Keypad Access	24
5.5.	Return from the Programming Levels and Time-Out Function	24
5.6.	Reset all Parameters to Factory Default Values	24
6.	Menu Structure and Description of Parameters	25
6.1.	Summary of the Menu	25
6.2.	Description of the Parameters	27
7.	Important Hints for the User	38
7.1.	Description of keypad commands and remote commands	38
7.2.	Hints for Scaling of the Unit	40
7.3.	Example for the Function of the Digital Filter	42
7.4.	Internal Self-Testing Functions of the Monitor	43
7.5.	Manual Release of a Self-Testing Cycle	44
7.6.	Behavior in Case of Error, Error Messages	45
7.7.	Display of Switching Functions and Principle of Operation of Parameter "Target Display"	46
7.8.	Temporary Interruption of the Display of Switching States	47
7.9.	Operation of the Watchdog Function	47
7.10.	Behavior of the Monitor after Power up	47
8.	Serial Access Codes	48
9.	Technical Specifications	53
10.	Dimensions	54

1. Introduction and Application

The MS640 motion monitor has been designed for monitoring and control of admissible and impermissible operating conditions on machinery systems. This unit is not just a speed monitor, but provides comparison between peripheral motion, motor motion and actual operator commands. The control functions include all actual values of two independent encoders (speeds, directions of rotation, standstill, positions and differential positions between the two encoders). The MS640 monitor is intended to generate alarms upon programmable coincidence of measuring values and events by means of four relay outputs and four transistor outputs.

The example below shows a hoisting unit where a motor moves the load up and down, via gearbox or other mechanical transmission.

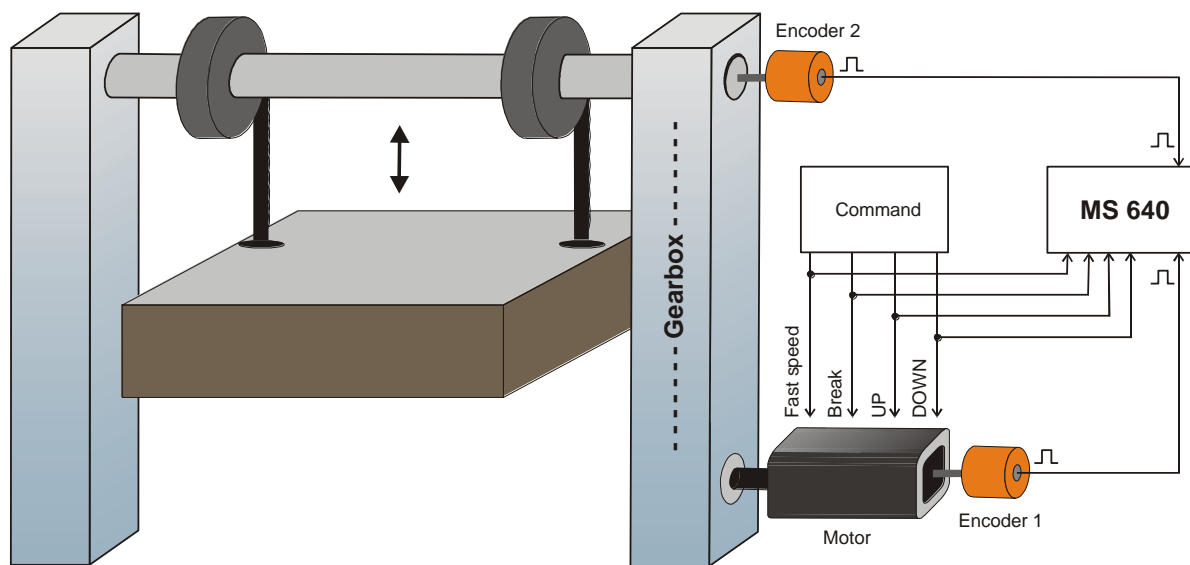

In a situation like shown the MS640 unit could e.g. provide the following alarms:

- The operator command is "UP" but the motor or the load do not reach the scheduled speed in time (overload or mechanical problem)
- No move command is applied and the break is engaged, but still the motor or the load are moving (break problem)
- The commands are "Slow" and "Down" but the actual speed of the load exceeds the permissible "Slow Speed" limit
- the displacement of the load indicated by encoder 2 does not match up with the number of pulses generated by encoder 1, with consideration of the gearbox ratio (slip problem)

Furthermore the MS640 can take over limit switch functions for the permissible upper and lower positions of the load etc. All desired functions can be easily configured by PC, just by clicking a few checkboxes in a "logical AND / OR" matrix on the screen.



MS 640 provides various internal safety functions and automatic self-test routines in order to ensure a maximum of functional safety for the whole monitoring system (see 7.4 - 7.9).

2. Electrical Connections

2.1. Connection Diagram

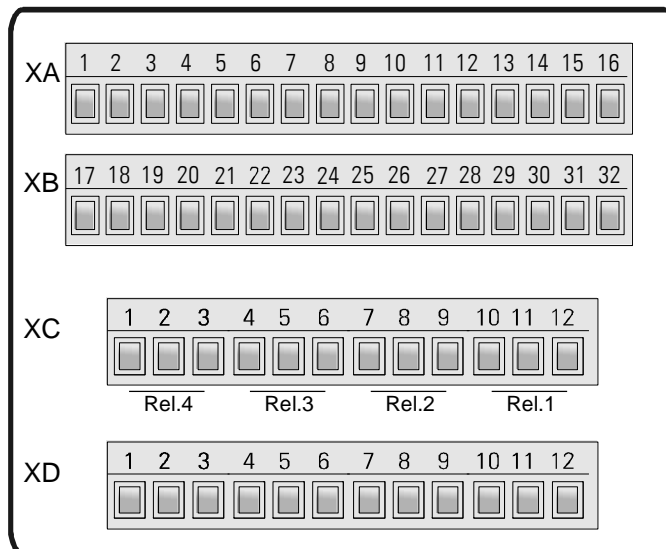
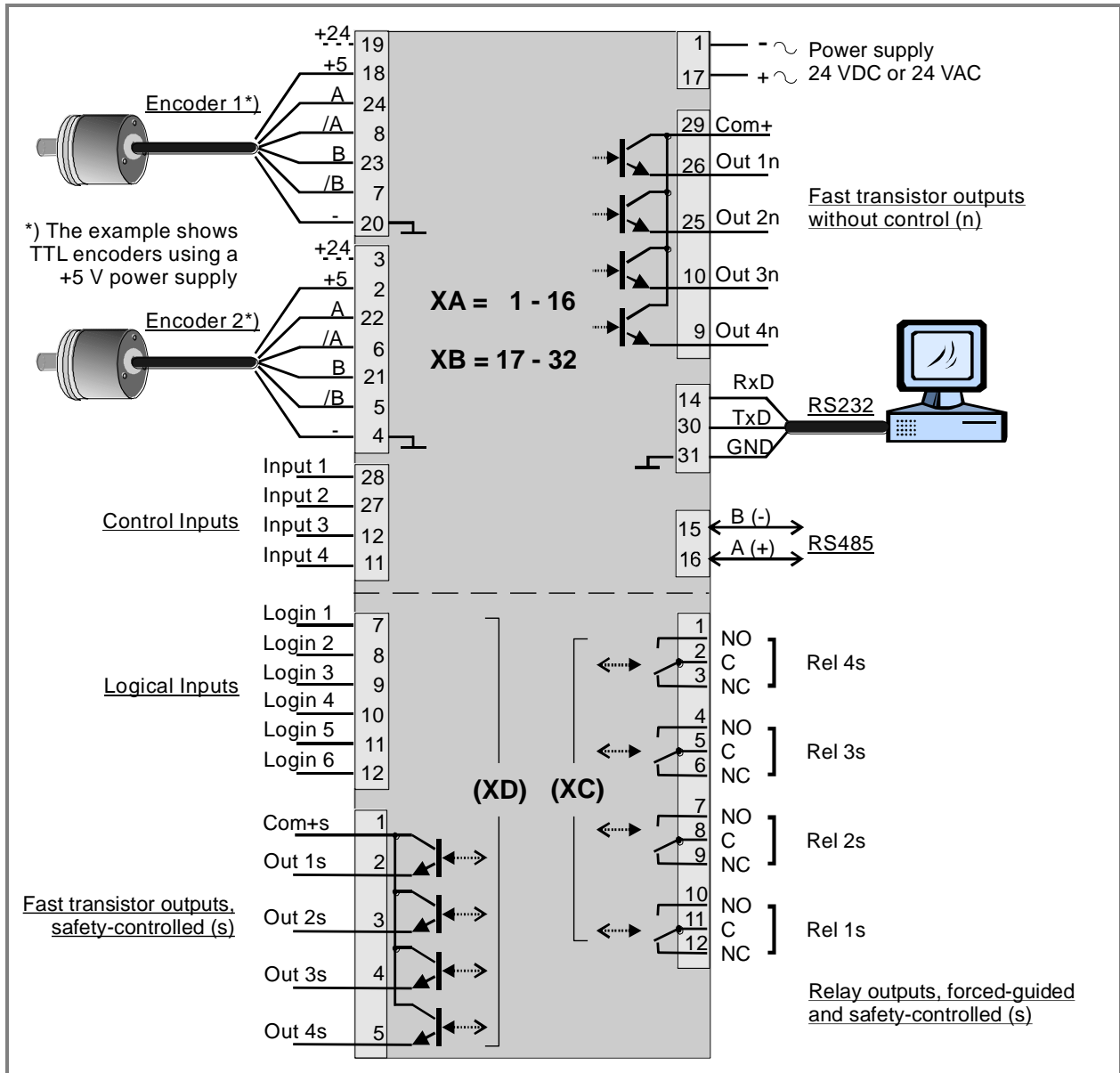

2.2. Terminal Assignments

XA/XB	Name	Function
01	GND	Common Ground Potential (0V)
02	+5,2V out	Aux. output 5.2V/150 mA for encoder supply
03	+24V out	Aux. output 24V/120 mA for encoder supply
04	GND	Common Ground Potential (0V)
05	Encoder 2, /B	Encoder 2, channel /B (B inverted)
06	Encoder 2, /A	Encoder 2, channel /A (A inverted)
07	Encoder 1, /B	Encoder 1, channel /B (B inverted)
08	Encoder 1, /A	Encoder 1, channel /A (A inverted)
09	Out 4n	Digital output, transistor PNP 30 volts, 350 mA (no safety feedback)
10	Out 3n	Digital output, transistor PNP 30 volts, 350 mA (no safety feedback)
11	Input 4	Programmable control input
12	Input 3	Programmable control input
13	(PROG)	(for download of new firmware only, not for general use)
14	RxD	Serial RS232 interface, input (Receive Data)
15	RS485 B (-)	RS 485 serial interface
16	RS485 A (+)	RS 485 serial interface
17	+Vin	Power supply input, +17 – 40 VDC or 24 VAC
18	+5,2V out	Aux. output 5,2V/150 mA for encoder supply
19	+24V out	Aux. output 24V/120 mA for encoder supply
20	GND	Common Ground Potential (0V)
21	Encoder 2, B	Encoder 2, channel B (non-inverted)
22	Encoder 2, A	Encoder 2, channel A (non-inverted)
23	Encoder 1, B	Encoder 1, channel B (non-inverted)
24	Encoder 1, A	Encoder 1, channel A (non-inverted)
25	Out 2n	Digital output, transistor PNP 30 volts, 350 mA (no safety feedback)
26	Out 1n	Digital output, transistor PNP 30 volts, 350 mA (no safety feedback)
27	Input 2	Programmable control input
28	Input 1	Programmable control input
29	Com+	Common positive input for transistor outputs Out 1n - Out 4n
30	TxD	Serial RS232 interface, output (Transmit Data)
31	GND	Common Ground Potential (0V)
32	GND	Common Ground Potential (0V) for DC or AC power supply

*) 120 mA and 150 mA are per encoder, i.e. total maximum currents are 240 mA and 300 mA

XC	Name	Function
01	Rel4-NO	Relais 4, Schließer
02	Rel4---C	Relais 4, gemeinsamer Kontakt
03	Rel4-NC	Relais 4, Öffner
04	Rel3-NO	Relais 4, Schließer
05	Rel3---C	Relais 4, gemeinsamer Kontakt
06	Rel3-NC	Relais 4, Öffner
07	Rel2-NO	Relais 4, Schließer
08	Rel2---C	Relais 4, gemeinsamer Kontakt
09	Rel2-NC	Relais 4, Öffner
10	Rel1-NO	Relais 4, Schließer
11	Rel1---C	Relais 4, gemeinsamer Kontakt
12	Rel1-NC	Relais 4, Öffner

XD	Name	Function
01	Com +s	Eingang für die Schaltspannung der Ausgänge Out 1s - Out 4s
02	Out 1s	Digitalausgang, Transistor PNP 30 V, 350 mA (gesichert)
03	Out 2s	Digitalausgang, Transistor PNP 30 V, 350 mA (gesichert)
04	Out 3s	Digitalausgang, Transistor PNP 30 V, 350 mA (gesichert)
05	Out 4s	Digitalausgang, Transistor PNP 30 V, 350 mA (gesichert)
06	GND	Gemeinsames Potenzial GND
07	Login 1	Eingang für Logikverknüpfungen Login1
08	Login 2	Eingang für Logikverknüpfungen Login2
09	Login 3	Eingang für Logikverknüpfungen Login3
10	Login 4	Eingang für Logikverknüpfungen Login4
11	Login 5	Eingang für Logikverknüpfungen Login5
12	Login 6	Eingang für Logikverknüpfungen Login6

2.3. Power Supply

The MS640 monitor accepts both, a 17 – 40 volts DC power or a 24 volts AC power for supply via terminals XA-1 and XB-17. The current consumption depends on the level of the input voltage and some internal conditions; therefore it can vary in a range from 100 – 200 mA (aux. currents taken from the unit for encoder supply not included).

2.4. Auxiliary Outputs for Encoder Supply

Terminals 2 and 18 provide an auxiliary output with approx. +5.2 volts DC (300 mA totally).
Terminals 3 and 19 provide an auxiliary output with approx. +24 volts DC (240 mA totally)

2.5. Impulse Inputs for Incremental Encoders

All input characteristics of the impulse inputs can be set by the parameter menu, for each of the encoders separately.

Due to the high safety demands made on this unit it is mandatory to use quadrature encoders only (A, B or A, /A, B, /B, 90°)

The following levels and impulse standards can be used:

- Symmetric inputs (differential) according to RS422 standard (A, /A; B, /B, minimum differential voltage 1 V)
- Differential TTL inputs with 3.0 to 5 volts level (A, /A; B, /B, minimum differential voltage 1 V)
- Differential HTL inputs with 10 – 30 volts level (A, /A; B, /B, minimum differential voltage 1 V)
- Single-ended HTL inputs with 10 - 30 volts level (channels A and B only)
- Single-ended TTL inputs with 3.0 to 5 volts level *) (channels A and B only)

*) For exceptional application only, since sensitive to EMC interference.
Requires special settings of the threshold parameters, see “Special parameters F10”

2.6. Control Inputs 1 – 4

These inputs can be configured for remote functions like Reset, disable of the keyboard or display selection purpose etc. All control inputs require HTL level (12 ... 30 volts). The characteristics can be individually set to either NPN (switch to -) or PNP (switch to +). For applications where edge-triggered action is needed, the menu allows to set the active edge (rising or falling). The control inputs will also accept signals according to Namur standard.



For reliable operation of the control inputs, minimum impulse duration of 50 µsec. must be ensured. Please verify that this minimum duration will be kept even at maximum speed of the machine

2.7. Logical Inputs Login1 - 6

The logical inputs are available for process control. These inputs receive logical information from the process (e.g. actual operator commands or limit switch information). The monitor can compare this information to the feedback information of the encoders and verify if the operator command is executed correctly or not.

Each of the 6 inputs provides programmable switch-on and switch-off delays, in order to allow acceptable response delays to electrical and mechanic parts before comparing the actual state and the scheduled state.

All logical inputs operate at HTL level (12 ... 30 volts) with PNP (switch to +) characteristics.

2.8. High Speed Transistor Outputs

Out 1n - Out 4n (n = normal) and Out 1s - Out 4s (s = safe)

The MS640 monitor provides 2 x 4 fast-switching transistor outputs, all short-circuit-proof, with a switching capability 5 - 30 volts / 350 mA each (response time < 1 msec.)

The functions of outputs Out 1n - Out 4n are in parallel to the functions of outputs Out 1s to Out 4s, so that only 4 different switching functions can be assigned to the 8 outputs.

Out 1n - Out 4n operate without internal feedback and without control of their switching state. Out 1s to Out 4s provide internal feedback with continuous control of the correct output state as well as monitoring of overload, short-circuit and idle state (cable break)



When one of the outputs Out 1s - Out 4s is not used or remains unconnected, it must be deactivated by means of parameter "Output Error Config.", otherwise a permanent "cable break" alarm will be indicated

2.9. Forced-Guided Safety Relays Rel.1s - Rel.4s

The four relays provide two dry change-over contacts each with forced-guided mechanical construction. The switching capability is 250 VAC / 1 A / 250 VA or 100 VDC / 1 A / 100 W and the response time of the relays is in a range of 5 to 10 msec.

In each case one set of the forced-guided contact pair is available for the user whereas the other contact set is used for internal feedback control. The processor monitors at any time, with consideration of the operate times of the relays, if the contact position coincides with the internal excitation of the coil, and discrepancies will cause an immediate alarm.



The following chapters describe how to assign control and switching functions to the relays and the outputs. For programming of the switching conditions a PC with operator software OS32 is used. The multitude of possible combinations between input information (logical states), encoder feedback (actual states) and programmable switching levels offers outstanding options for safety-related motion monitoring of all kinds of machinery.

It is possible to add any of the following characteristics to the resulting switching functions:

- Positive or negative response (active switching state ON or OFF)
- Switch-on and switch-off delays: the switching function will become active after programmable on-off times only to allow the mechanics to respond
- Timed or static operation: when the event occurs, the output can provide either dynamic (timed) operation or static operation
- Programmable catch functions with or without power-down storage: All switching functions can be set to "Lock" so that the corresponding switching function remains active until operator reset

2.10. Serial Interface

The serial RS232 interface can be used for the following purposes:

- Set-up of the unit by PC by means of the OS32 PC software
- Change of parameters during operation
- Readout of actual speeds or positions or other counter values by PLC or PC
- Running of functional checks of the monitor, under remote control of a superior system

The figure below shows how to connect the MS640 monitor to a PC or a PLC

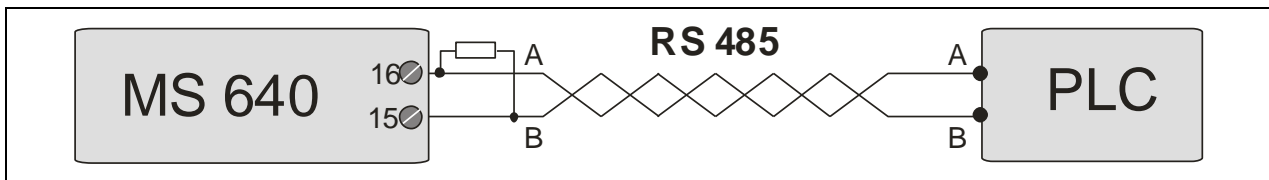
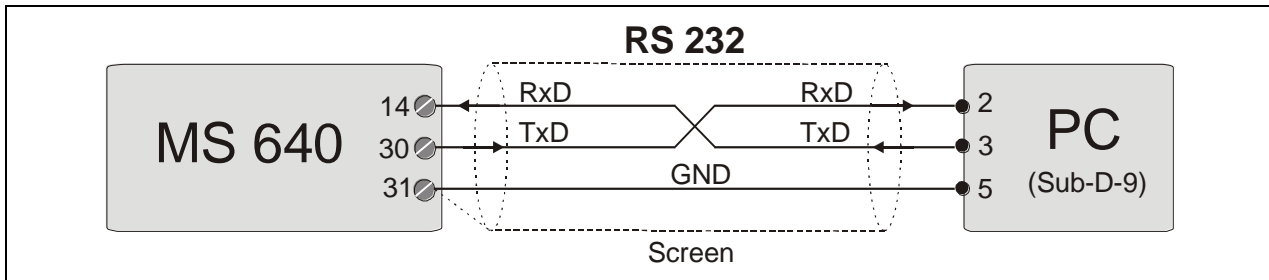

Both serial interfaces can be connected at the same time.
However only the one or the other must communicate at a time.
It is not possible to communicate simultaneously with both interfaces

3. Relevant Process Data and Setpoints

3.1. Available Actual Values

Depending on the connected encoders and sensors, the monitor continuously measures and updates the actual values shown in the list below. This means that every of these actual values is available at any time for evaluation and can be combined with other functions to switch one of the outputs ON or OFF.

Value/State	Description	Requirement
Standstill 1	Digital information (yes/no) for zero motion of encoder 1 *)	Incremental signal on Encoder 1 input
Motion signal 1	Digital information (yes/no) for active motion of encoder 1	Incremental signal on Encoder 1 input
Speed 1	Actual speed of encoder 1 according to customer scaling	Incremental signal on Encoder 1 input
Position 1	Actual position count of encoder 1 according to customer scaling **)	Quadrature encoder for encoder input 1
Direction 1	Direction of motion (forward or reverse) of encoder 1	Quadrature encoder for encoder input 1
Standstill 2	Digital information (yes/no) for zero motion of encoder 2 *)	Incremental signal on Encoder 2 input
Motion signal 2	Digital information (yes/no) for active motion of encoder 2	Incremental signal on Encoder 2 input
Speed 2	Actual speed of encoder 2 according to customer scaling	Incremental signal on Encoder 2 input
Position 2	Actual position count of encoder 2 according to customer scaling **)	Quadrature encoder for encoder input 2
Direction 2	Direction of motion (forward or reverse) of encoder 2	Quadrature encoder for encoder input 2
Difference Pos 1 - Pos 2	Differential position count between encoder 1 and encoder 2, according to customer scaling **)	Quadrature encoders for both, encoder 1 and encoder 2

*) Standstill can be defined by parameter setting

***) "Zero position" and "Zero difference" can be defined by individual RESET

3.2. Available Setpoints

For configuration of the switching conditions of the relays, the following setpoints are available. Every setting is individual for each of the four switching functions.

In total there are $4 \times 7 = 28$ programmable setpoints available.

Settings can be omitted if the corresponding setpoints have not been assigned to a switching function.

Setpoint	Description
Set Speed 1.1	Set Speed 1 for Encoder 1
Set Speed 1.2	Set Speed 2 for Encoder 1
Set Speed 2.1	Set Speed 1 for Encoder 2
Set Speed 2.2	Set Speed 2 for Encoder 2
Setpoint Counter 1	Position setpoint for Encoder 1
Setpoint Counter 2	Position setpoint for Encoder 2
Differential Setpoint	Differential position setpoint (encoder 1 – encoder 2)

3.3. Available Criteria for Combination of Switching Events

Every of the four available output functions provides 4 programmable switching events which can again be combined from several switching conditions (logical AND).

As soon as one or several of the four events become true, the corresponding function will be activated or deactivated (logical OR) and as a result one of the output according to assignment will switch on or off (see 3.4 and 4.3).

3.3.1. Logical switching conditions

Condition	Description of the Switching Condition
Login1 or /Login1	All functions allow gating with one or several of the 6 logical Inputs. <ul style="list-style-type: none"> - Login X means that a "HIGH" signal is needed to make the condition true - /Login X means that a "LOW" signal is needed to make the condition true
Login2 or /Login2	
Login3 or /Login3	
Login4 or /Login4	
Login5 or /Login5	
Login6 or /Login6	

3.3.2. Speed related switching conditions

Condition	Description of the Switching Condition
$[v1] \leq \text{Set Speed1.1}$	The absolute value of the actual encoder1 speed is lower or equal to the set speed 1.1
$[v1] \geq \text{Set Speed1.1}$	The absolute value of the actual encoder1 speed is higher or equal to the set speed 1.1
$[v1] \geq \text{Set Speed1.2}$	The absolute value of the actual encoder1 speed is higher or equal to the set speed 1.2
$[v1] = 0$	Speed of encoder1 = zero (standstill according to standstill definition)
$[v1] \neq 0$	Speed of encoder1 \neq zero (encoder1 is in motion)
$[v2] \leq \text{Set Speed2.1}$	The absolute value of the actual encoder2 speed is lower or equal to the set speed 2.1
$[v2] \geq \text{Set Speed2.1}$	The absolute value of the actual encoder2 speed is higher or equal to the set speed 2.1
$[v2] \geq \text{Set Speed2.2}$	The absolute value of the actual encoder2 speed is higher or equal to the set speed 2.2
$[v2] = 0$	Speed of encoder2 = zero (standstill according to standstill definition)
$[v2] \neq 0$	Speed of encoder2 \neq zero (encoder2 is in motion)

3.3.3. Position related switching conditions

Condition	Description of the Switching Condition
$[c1] \geq \text{Setpoint Counter1}$	The absolute value of the actual encoder1 counter is higher or equal to "Position Setpoint 1" of the corresponding function
$[c1] \leq \text{Setpoint Counter1}$	The absolute value of the actual encoder1 counter is lower or equal to "Position Setpoint 1" of the corresponding function
$[c2] \geq \text{Setpoint Counter2}$	The absolute value of the actual encoder2 counter is higher or equal to "Position Setpoint 2" of the corresponding function
$[c2] \leq \text{Setpoint Counter2}$	The absolute value of the actual encoder2 counter is lower or equal to "Position Setpoint 2" of the corresponding function

3.3.4. Direction related switching conditions

Condition	Description of the Switching Condition
$c1 = + + +$	Counter 1 counts upwards, Direction1 = Forward
$c1 = - - -$	Counter 1 counts downwards, Direction1 = Reverse
$c2 = + + +$	Counter 2 counts upwards, Direction2 = Forward
$c2 = - - -$	Counter 2 counts downwards, Direction2 = Reverse

3.3.5. Differential switching conditions

Event	Description of the Switching Condition
$[c1 - c2] \geq \text{Differential Setpoint}$	The absolute value of the differential position between encoder1 and encoder2 is higher or equal to the differential position setpoint of the corresponding function
$[c1 - c2] \leq \text{Differential Setpoint}$	The absolute value of the differential position between encoder1 and encoder2 is higher or equal to the differential position setpoint

3.4. Generation of an Output Signal

As a first step we have to arrange the desired Switching Events, which can be composed from any combination of the switching conditions as described above. Every event consists of one or several conditions according to the selection of check boxes on the PC screen (see 4.3). Several events (1 - 4) are combined to a Switching Function. The parameters named "Target Function" allow the assignment of an output to each function, where the switching signal finally appears. Also the internal status bits become accessible via output if a corresponding assignment has been made. The assignment of outputs uses an 8-bit binary code as shown below.

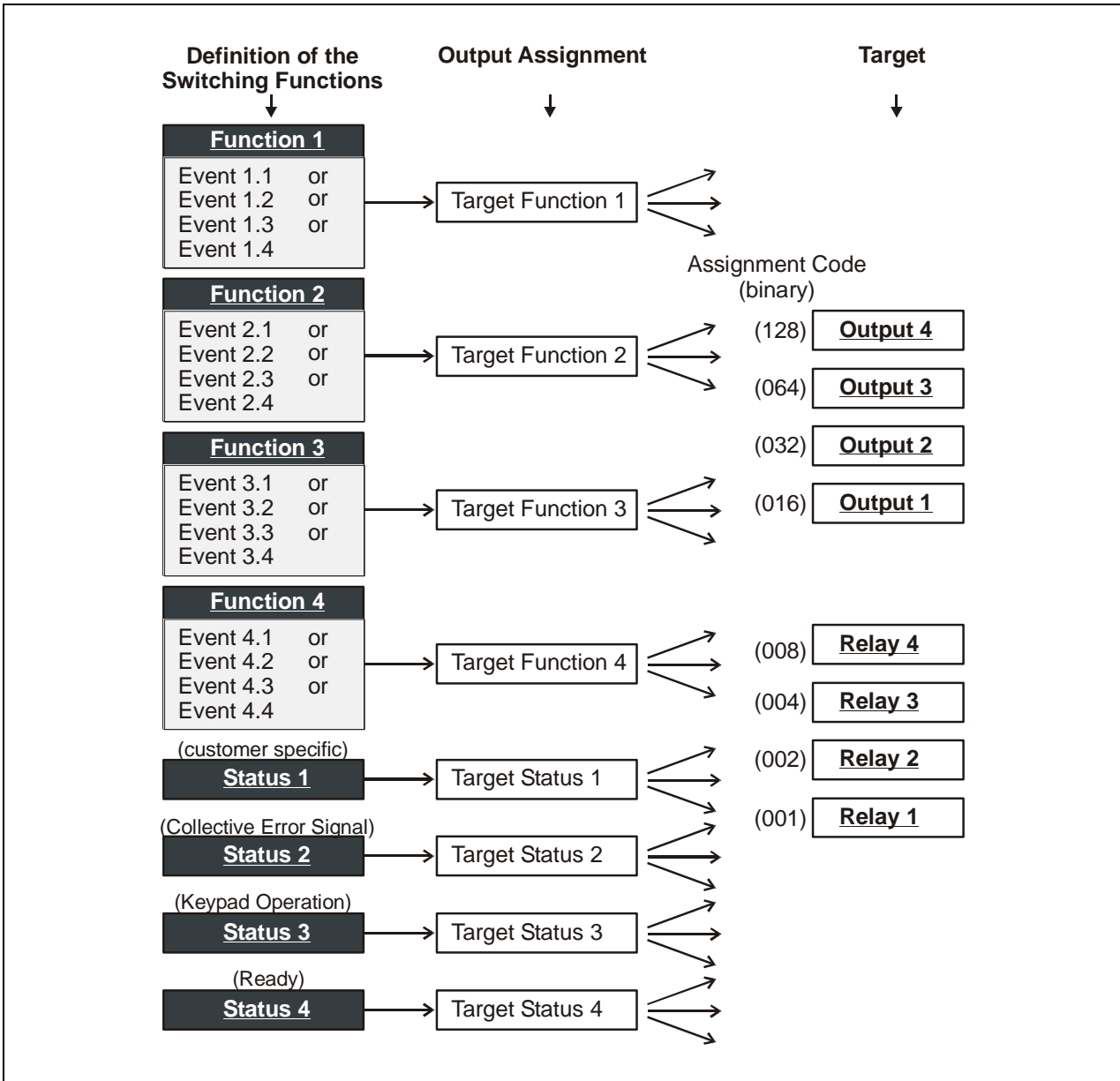

3.5. Indication of Switching Functions

With some applications it can be useful to just present actual events and switching functions on the display without affecting an alarm output. Similarly a visual display of actually active events may be desirable in addition to an alarm output. Therefore, quite according to the parameters "Target Function", the parameters "Target Display" provide assignment of a display function to the switching functions, which can either be used alone or together with an output action. All corresponding details are explained in chapter 7.7.

3.6. Operation of the Status Signals

3.6.1. Status 4 (Ready)

This status signal is active (log. 1) to indicate that the hardware of the unit is ready for proper operation and no fault could be detected inside the monitor itself (see chapter 7.4).

3.6.2. Status 3 (Keypad Operation)

During any access to the parameters via the keypad of the unit itself, all external monitoring functions are temporary disabled. A logical "1" state of this signal indicates that the control functions are disabled due to keypad access to the unit. At the same time also the Ready signal is switched off. *)

3.6.3. Status 2 (Collective Error Signal)

This status signal is active (log. 1) to indicate that an error or an abnormality has been detected during the automatic self-testing routines running continuously in the background, At the same time the Ready signal will switch off and an error code will be generated and indicated on the LED display. A fully itemized error code is also accessible via serial link (see 7.6 for details)

3.6.4. Status 1 (customer-specific)

This signal is reserved for customer-specific use according to agreement. With all standard units the Status 1 signal is permanently switched off.

*) It is at any time possible to read out or to change parameters and settings by communication via serial interface, while all control remains fully active and no functions will be disabled

4. Setup of the Unit by PC

4.1. PC connection

For initial setup of the MS640 Motion Monitor a PC with the motrona OS32 operator software is required (Software version OS32_02a or higher). This software is included on CD and is also available for free download from our homepage www.motrona.com.

The software allows to set all basic parameters and to assign the desired switching functions to the outputs. During later operation, the four programming keys on the front side of the unit can be used to change settings like Setpoints or scaling parameters (see chapter 5).

Connect your PC to the monitor as shown under 2.7 and start the OS32 software.
The adjoining screen will appear.

If your text and color fields remain empty and the headline says „OFFLINE“, you must verify your serial settings. To do this, please select “Comms” from the menu bar.



- Ex factory, all motrona units use the following serial standard settings:
Unit No. 11, Baud rate 9600, 1 start/ 7 data/ parity even/ 1 stop bit
- If the serial settings of your unit should be unknown, you can run the “SCAN” function from the „TOOLS” menu to find out.

4.2. The Main Screen

The edit window for all unit parameters can be found on the left side of the screen.
To enter your parameters, please click to the corresponding line, enter a new value and save the new value by pressing ENTER on your PC keyboard.

You can also just change all digits according to need, then finally click to the Softkeys “Transmit All” followed by “Store EEPROM” to save all your settings.

The INPUTS field provides Softkeys to switch the control commands on or off.
Display boxes in the RS column indicate when the corresponding command is set to ON by PC.
Display boxes in the PI/O column indicate that commands assigned to the hardware inputs (input1 to input4) are switched ON by external signal.

Command "Select Variables" (marked by red pointer in the screenshot) is reserved for factory use only. For normal operation this command must be inactive (off) at any time to allow proper use of the PC software.

The OUTPUT field informs about the actual switching state of the four outputs Out1 - Out4 and the four relays Rel1 - Rel4.

4.3. PC Screen for Configuration of Switching Functions

To open the Assignment screen, select "Config. MM/MS" from the Tools Menu.

You can assign any combination of switching events and functions to the outputs or relays by clicking to the corresponding boxes of conditions as described before.

In the "Options" column you find a list of all actual motion conditions as described under 3.3

Checkboxes allow activation or deactivation of the corresponding event as one of the desired switching conditions (click the corresponding box to switch it on or off).



- All checkboxes of a vertical column (representing conditions) operate "Logical AND" and form a "Switching Event."
- Always four adjoining columns (events) operate "Logical OR" and form a Switching Function. If one or several of the events become true, the switching function will become active.
- You are free to activate any number and combination of checkboxes. Setting checkboxes with conflictive conditions should however be avoided. *)
- The destination output for each switching function can be set by means of the parameter "Target Function".

It is possible to assign different switching functions to the same output (e.g. Function1 => Relay1 and Function2 => Relay1)

Likewise it is possible to assign several outputs to the same switching function (e.g. Function1 => Relay1 and Relay2)

*) Where e.g. you would set both checkboxes "v=0" and "v≠0" at the same time, this would result in a conflict where the corresponding output would never switch off.

The adjoining screenshot shows the following four events to activate Switching Function 1:

Login1 = LOW and Login2 = High and Encoder1 = Standstill

(event 1.1)

or

Login2 = High and Speed1 ≥ Set Speed1.1 and Forward Motion of Encoder1

(event 1.2)

or

Login3 = High

(event 1.3)

or

Reverse motion of Encoder 2

(event 1.4)

It is easy to understand how many possibilities of monitoring speeds and events result from this simple method of programming.





Options	Function1	Function2	Function3	Function4
/Login 1 (low)	1.1 <input checked="" type="checkbox"/>	2.1 <input type="checkbox"/>	3.1 <input type="checkbox"/>	4.1 <input type="checkbox"/>
/Login 2 (low)	1.2 <input type="checkbox"/>	2.2 <input type="checkbox"/>	3.2 <input type="checkbox"/>	4.2 <input type="checkbox"/>
/Login 3 (low)	1.3 <input type="checkbox"/>	2.3 <input type="checkbox"/>	3.3 <input type="checkbox"/>	4.3 <input type="checkbox"/>
/Login 4 (low)	1.4 <input type="checkbox"/>	2.4 <input type="checkbox"/>	3.4 <input type="checkbox"/>	4.4 <input type="checkbox"/>
/Login 5 (low)	<input type="checkbox"/>	<input type="checkbox"/>	<input type="checkbox"/>	<input type="checkbox"/>
/Login 6 (low)	<input type="checkbox"/>	<input type="checkbox"/>	<input type="checkbox"/>	<input type="checkbox"/>
Login 1 (high)	<input type="checkbox"/>	<input type="checkbox"/>	<input type="checkbox"/>	<input type="checkbox"/>
Login 2 (high)	<input checked="" type="checkbox"/>	<input type="checkbox"/>	<input type="checkbox"/>	<input type="checkbox"/>
Login 3 (high)	<input type="checkbox"/>	<input type="checkbox"/>	<input type="checkbox"/>	<input type="checkbox"/>
Login 4 (high)	<input type="checkbox"/>	<input type="checkbox"/>	<input type="checkbox"/>	<input type="checkbox"/>
Login 5 (high)	<input type="checkbox"/>	<input type="checkbox"/>	<input type="checkbox"/>	<input type="checkbox"/>
Login 6 (high)	<input type="checkbox"/>	<input type="checkbox"/>	<input type="checkbox"/>	<input type="checkbox"/>
V1 <= Set Speed 1.1	<input type="checkbox"/>	<input type="checkbox"/>	<input type="checkbox"/>	<input type="checkbox"/>
V1 >= Set Speed 1.1	<input checked="" type="checkbox"/>	<input type="checkbox"/>	<input type="checkbox"/>	<input type="checkbox"/>
V1 >= Set Speed 1.2	<input type="checkbox"/>	<input type="checkbox"/>	<input type="checkbox"/>	<input type="checkbox"/>
V1 = 0	<input checked="" type="checkbox"/>	<input type="checkbox"/>	<input type="checkbox"/>	<input type="checkbox"/>
V1 != 0	<input type="checkbox"/>	<input type="checkbox"/>	<input type="checkbox"/>	<input type="checkbox"/>
V2 <= Set Speed 2.1	<input type="checkbox"/>	<input type="checkbox"/>	<input type="checkbox"/>	<input type="checkbox"/>
V2 >= Set Speed 2.1	<input type="checkbox"/>	<input type="checkbox"/>	<input type="checkbox"/>	<input type="checkbox"/>
V2 >= Set Speed 2.2	<input type="checkbox"/>	<input type="checkbox"/>	<input type="checkbox"/>	<input type="checkbox"/>
V2 = 0	<input type="checkbox"/>	<input type="checkbox"/>	<input type="checkbox"/>	<input type="checkbox"/>
V2 != 0	<input type="checkbox"/>	<input type="checkbox"/>	<input type="checkbox"/>	<input type="checkbox"/>
Z1 >= Setpoint Counter 1	<input type="checkbox"/>	<input type="checkbox"/>	<input type="checkbox"/>	<input type="checkbox"/>
Z1 <= Setpoint Counter 1	<input type="checkbox"/>	<input type="checkbox"/>	<input type="checkbox"/>	<input type="checkbox"/>
Z1 = ++	<input checked="" type="checkbox"/>	<input type="checkbox"/>	<input type="checkbox"/>	<input type="checkbox"/>
Z1 = --	<input type="checkbox"/>	<input type="checkbox"/>	<input type="checkbox"/>	<input type="checkbox"/>
Z2 >= Setpoint Counter 2	<input type="checkbox"/>	<input type="checkbox"/>	<input type="checkbox"/>	<input type="checkbox"/>
Z2 <= Setpoint Counter 2	<input type="checkbox"/>	<input type="checkbox"/>	<input type="checkbox"/>	<input type="checkbox"/>
Z2 = ++	<input type="checkbox"/>	<input type="checkbox"/>	<input type="checkbox"/>	<input type="checkbox"/>
Z2 = --	<input type="checkbox"/>	<input type="checkbox"/>	<input type="checkbox"/>	<input type="checkbox"/>
[Z1-Z2] >= Differential Setpoint	<input type="checkbox"/>	<input type="checkbox"/>	<input type="checkbox"/>	<input type="checkbox"/>
[Z1-Z2] <= Differential Setpoint	<input type="checkbox"/>	<input type="checkbox"/>	<input type="checkbox"/>	<input type="checkbox"/>

Leave without save
Exit
Transmit

5. Keypad Operation

An overview of all parameters and explanations can be found under section 6.

The menu of the unit uses four keys, hereinafter named as follows:

			
PROG	UP	DOWN	ENTER

Key functions depend on the actual operating state of the unit. Essentially we have to describe two basic states:

- Normal operation
- General setup procedure

5.1. Normal Operation

In this mode the unit operates as a motion monitor according to the settings defined upon setup. All front keys may have customer-defined functions according to the specifications met in the keypad definition menu F08 (e.g. Reset, Display selection or else). During normal operation the internal status "Ready" indicates the operating state of the unit.









5.2. General Setup Procedure

The unit changes over from normal operation to setup level when keeping the  key down for at least 2 seconds. Thereafter you can select one of the parameter groups F01 to F11.

Inside the group you can now select the desired parameter and set the value according to need. After this you can either set more parameters or return to the normal operation.

During all setup operations by keypad the "Ready" status is OFF while the "Keypad Operation" status is ON.

The adjoining sequence of key operations explains how to change **Parameter number 052 of group F06 from the original value of 0 to a new value of 8**





Step	State	Key action		Display	Comment
00	Normal operation			Actual Display Value	
01			> 2 sec.	F01	Display of the Parameter group
02	Level: Parameter group		5 x	F02 ... F06	Select group # F06
03				F06.050	Confirmation of F06. The first parameter of this group is F06.050
04	Level: Parameter numbers		2 x	F06.051 ... F06.052	Select parameter 052
05				0	Parameter 052 appears in display, actual setting is 0
06	Level: Parameter values		8 x	1 8	Setting has been modified from 0 to 8
07				F06.052	Save the new setting (8)
08	Level: Parameter numbers			F06	Return to level parameter groups
09	Level: Parameter groups			Actual Display value	Return to normal operation
10	Normal operation				



During the general setup procedure all control and monitoring activities remain disabled. Status "Ready" will be LOW state and Status "Keypad Operation" will be HIGH.
New parameter settings become active after return to normal operation only.











5.3. Change of Parameter Values on the Numeric Level

The numeric range of the parameters is up to 6 digits. Some of the parameters may also include a sign. For fast and easy setting of these values the menu uses an algorithm as shown subsequently. During this operation the front keys have the following functions:

			
PROG	UP	DOWN	ENTER
Saves the actual value shown in the display and returns to the parameter selection level	Increments the highlighted (blinking) digit	Decrements the highlighted (blinking) digit	Shifts the cursor (blinking digit) one position to the left, or from utmost left to right

With signed parameters the left digit scrolls from **0 to 9** and then shows “-,” (negative) and “-1” (minus one).

The example below shows how to change a parameter from the actual setting of 1024 to the new setting of 250 000. This example assumes that you have already selected the parameter group and the parameter number, and that you actually read the parameter value in the display. Highlighted digits appear on colored background.

Step	Display	Key action	Comment
00	001024		Display of actual parameter setting, last digit is highlighted
01		 4 x	Scroll last digit down to 0
02	001020		Shift cursor to left
03	001020	 2 x	Scroll highlighted digit down to 0
04	001000	 2 x	Shift cursor 2 positions left
05	001000		Scroll highlighted digit down to 0
06	000000		Shift cursor left
07	000000	 5 x	Scroll highlighted digit up to 5
08	050000		Shift cursor left
09	050000	 2 x	Scroll highlighted digit up to 2
10	250000		Save new setting and return to the parameter number level

5.4. Code Protection against Unauthorized Keypad Access

Parameter group F11 allows to define an own locking code for each of the parameter menus. This permits to limit access to certain parameter groups to specific persons only.

When accessing a protected parameter group, the display will first show "CODE" and wait for your entry. To continue keypad operations you must now enter the code which you have stored before, otherwise the unit will return to normal operation again.

After entering your code, press the ENTER key and keep it down until the unit responds. When your code was correct, the response will be "YES" and the menu will work normally. With incorrect code the response will be "NO" and the menu remains locked.

5.5. Return from the Programming Levels and Time-Out Function

At any time the PROG key sets the menu one level up and finally returns to normal operation. The same step occurs automatically via the time-out function, when during a period of 10 seconds no key has been touched.

Termination of the menu by automatic time-out will not store new settings, unless they have already been stored by the PROG key after editing.

5.6. Reset all Parameters to Factory Default Values

Upon special need it may be desirable to set all parameters back to their original factory settings (e.g. because you have forgotten your access code, or by too many change of settings you have achieved a complex parameter state). Default values are indicated in the parameter tables shown later.

To reset the unit to default, please take the following steps:

- Switch power off

- Press  and  simultaneously

- Switch power on while you keep down both keys



Where you decide to take this action, please note that all parameters and settings will be lost, and that you will need to run a new setup procedure again.

6. Menu Structure and Description of Parameters

All parameters are arranged in a reasonable order of functional groups (F01 to F11)
 You must only set those parameters which are really relevant for your specific application.
 Unused parameters can remain as they actually are.

6.1. Summary of the Menu

This section shows a summary of the parameter groups. Texts indications are corresponding to parameter names on the PC screen.

Group	Function	Group	Function
F01	Function 1 Settings	F03	Function 3 Settings
000	Set Speed 1.1	032	Set Speed 1.1
001	Set Speed 1.2	033	Set Speed 1.2
002	Set Speed 2.1	034	Set Speed 2.1
003	Set Speed 2.2	035	Set Speed 2.2
004	Setpoint Counter 1	036	Setpoint Counter 1
005	Setpoint Counter 2	037	Setpoint Counter 2
006	Differential Setpoint	038	Differential Setpoint
007	Switch Condition 1	039	Switch Condition 1
008	Switch Condition 2	040	Switch Condition 2
009	Switch Condition 3	041	Switch Condition 3
010	Switch Condition 4	042	Switch Condition 4
011	Switch on Delay	043	Switch on Delay
012	Pulse Time	044	Pulse Time
013	Lock Function	045	Lock Function
014	Polarity	046	Polarity
F02	Function 2 Settings	F04	Function 4 Settings
016	Set Speed 1.1	048	Set Speed 1.1
017	Set Speed 1.2	049	Set Speed 1.2
018	Set Speed 2.1	050	Set Speed 2.1
019	Set Speed 2.2	051	Set Speed 2.2
020	Setpoint Counter 1	052	Setpoint Counter 1
021	Setpoint Counter 2	053	Setpoint Counter 2
022	Differential Setpoint	054	Differential Setpoint
023	Switch Condition 1	055	Switch Condition 1
024	Switch Condition 2	056	Switch Condition 2
025	Switch Condition 3	057	Switch Condition 3
026	Switch Condition 4	058	Switch Condition 4
027	Switch on Delay	059	Switch on Delay
028	Pulse Time	060	Pulse Time
029	Lock Function	061	Lock Function
030	Polarity	062	Polarity

Gruppe	Funktion	Gruppe	Funktion
F05	Logical Inputs Delay Settings	F08	Command Setting
064	Login 1 On Delay	106	Key Up Action
065	Login 1 Off Delay	107	Key Down Action
066	Login 2 On Delay	108	Key Enter Action
067	Login 2 Off Delay	109	Input 1 Configuration
068	Login 3 On Delay	110	Input 1 Action
069	Login 3 Off Delay	111	Input 2 Configuration
070	Login 4 On Delay	112	Input 2 Action
071	Login 4 Off Delay	113	Input 3 Configuration
072	Login 5 On Delay	114	Input 3 Action
073	Login 5 Off Delay	115	Input 4 Configuration
074	Login 6 On Delay	116	Input 4 Action
075	Login 6 Off Delay	117	Target Function 1
F06	Encoder 1 Settings	118	Target Function 2
076	Factor Counter 1	119	Target Function 3
077	Multi. Counter 1	120	Target Function 4
078	DP Counter 1	121	Target Status 1
079	Dir Window Counter 1	122	Target Status 2
080	Multi. Speed 1	123	Target Status 3
081	Divi. Speed 1	124	Target Status 4
082	Offset Speed 1	125	Target Display
083	DP Speed 1	126	Release Action
084	Sampling Time 1	127	Freeze Action
085	Wait Time 1	128	Output Error Config
086	Filter 1	F09	Serial Settings
087	Encoder Properties 1	132	Unit Number
088	Edge Counting 1	133	Serial Baud Rate
089	Counting Direction 1	134	Serial Format
F07	Encoder 2 Settings	F10	Special Functions
091	Factor Counter 2	138	Input Filter
092	Multi. Counter 2	139	Trigger Threshold 1
093	DP Counter 2	140	Trigger Threshold 2
094	Dir Window Counter 2	141	Brightness
095	Multi. Speed 2	142	Display Time
096	Divi. Speed 2	143	Frequency Control
097	Offset Speed 2	144	Power Down
098	DP Speed 2	145	Target Display Break
099	Sampling Time 2	146	Start Display
100	Wait Time 2	F11	Keypad Protection Codes
101	Filter 2	147	Protect Group F01
102	Encoder Properties 2	148	Protect Group F02
103	Edge Counting 2		→
104	Counting Direction 2		→
			→
		156	Protect Group F10
		157	Protect Group F11

6.2. Description of the Parameters

6.2.1. Settings for Switching Function 1

F01		Range	Default
F01.000	Set Speed 1.1 First Setpoint for a switching condition of Function1 in dependence of the encoder1 speed	0 ... 999 999	11001
F01.001	Set Speed 1.2 Second Setpoint for a switching condition of Function1 in dependence of the encoder1 speed	0 ... 999 999	11002
F01.002	Set Speed 2.1 First Setpoint for a switching condition of Function1 in dependence of the encoder2 speed	0 ... 999 999	21001
F01.003	Set Speed 2.2 Second Setpoint for a switching condition of Function1 in dependence of the encoder2 speed	0 ... 999 999	21002
F01.004	Setpoint Counter 1 Value for comparison with the actual position of encoder 1 for a switching condition of Function1	0 ... 999 999	31000
F01.005	Setpoint Counter 2 Value for comparison with the actual position of encoder 1 for a switching condition of Function1	0 ... 999 999	41000
F01.006	Differential Setpoint Value for comparison with the actual position difference (encoder 1 - encoder 2) for a switching condition of Function1	0 ... 999 999	51000
F01.007	Switch Condition 1	Are automatically set by the assignment screen of the OS3.2 software and should not be modified	
F01.008	Switch Condition 2		
F01.009	Switch Condition 3		
F01.010	Switch Condition 4		

F01		Range	Default
F01.011	Switch on Delay Delay time between event appearance and switching response of Function 1. 0 = immediate response	0.000 ... 9.999 (sec.)	0.000
F01.012	Pulse Time Duration time of Switching Function 1 0 = static operation	0.000 ... 9.999 (sec.)	0.000
F01.013	Lock Function	0 ... 2	0
	0= Normal operation (no catch)		
	1= Catch function without storage: Once Function 1 got activated, only the external command "Release Function" or power off can clear the switching state		
2= Catch function with storage: Once Function 1 got activated, only the external command "Release Function" can clear the switching state. The lock situation will even continue after switching power off and on again.			
F01.014	Polarity	0 ... 1	0
	0= True Events set Function 1 to ON		
	1= True Events set Function 1 to OFF		

6.2.2. Settings for Switching Function 2 (Description see Function 1)

F02		Range	Default
F02.016	Set Speed 1.1	0 ... 999 999	12001
F02.017	Set Speed 1.2	0 ... 999 999	12002
F02.018	Set Speed 2.1	0 ... 999 999	22001
F02.019	Set Speed 2.2	0 ... 999 999	22002
F02.020	Setpoint Counter 1	0 ... 999 999	32000
F02.021	Setpoint Counter 2	0 ... 999 999	42000
F02.022	Differential Setpoint	0 ... 999 999	52000
F02.023	Switch Condition 1	Are automatically set by the assignment screen of the OS3.2 software and should not be modified	
F02.024	Switch Condition 2		
F02.025	Switch Condition 3		
F02.026	Switch Condition 4		
F02.027	Switch on Delay	0.000 ... 9.999	0.000
F02.028	Pulse Time	0.000 ... 9.999	0.000
F02.029	Lock Function	0 ... 2	0
F02.030	Polarity	0 ... 1	0

6.2.3. S Settings for Switching Function 3 (Description see Function 1)

F03		Range	Default
F03.032	Set Speed 1.1	0 ... 999 999	13000
F03.033	Set Speed 1.2	0 ... 999 999	23000
F03.034	Set Speed 2.1	0 ... 999 999	23000
F03.035	Set Speed 2.2	0 ... 999 999	23000
F03.036	Setpoint Counter 1	0 ... 999 999	33000
F03.037	Setpoint Counter 2	0 ... 999 999	43000
F03.038	Differential Setpoint	0 ... 999 999	53000
F03.039	Switch Condition 1	Are automatically set by the assignment screen of the OS3.2 software and should not be modified	
F03.040	Switch Condition 2		
F03.041	Switch Condition 3		
F03.042	Switch Condition 4		
F03.043	Switch on Delay	0.000 ... 9.999	0.000
F03.044	Pulse Time	0.000 ... 9.999	0.000
F03.045	Lock Function	0 ... 2	0
F03.046	Polarity	0 ... 1	0

6.2.4. Settings for Switching Function 4 (Description see Function 1)

F04		Range	Default
F04.048	Set Speed 1.1	0 ... 999 999	14000
F04.049	Set Speed 1.2	0 ... 999 999	24000
F04.050	Set Speed 2.1	0 ... 999 999	24000
F04.051	Set Speed 2.2	0 ... 999 999	24000
F04.052	Setpoint Counter 1	0 ... 999 999	34000
F04.053	Setpoint Counter 2	0 ... 999 999	44000
F04.054	Differential Setpoint	0 ... 999 999	54000
F04.055	Switch Condition 1	Are automatically set by the assignment screen of the OS3.2 software and should not be modified	
F04.056	Switch Condition 2		
F04.057	Switch Condition 3		
F04.058	Switch Condition 4		
F04.059	Switch on Delay	0.000 ... 9.999	0.000
F04.060	Pulse Time	0.000 ... 9.999	0.000
F04.061	Lock Function	0 ... 2	0
F04.062	Polarity	0 ... 1	0

6.2.5. Delay setting for logical Inputs

F05		Range	Default
F05.064	Login 1 On Delay The input must be HIGH for at least this delay time (seconds) to set the internal input state to high.	0.000 ... 9.999 0 = no delay, immediate response	0.000
F05.065	Login 1 Off Delay The input must be LOW for at least this delay time (seconds) to set the internal input state to low.	0.000 ... 9.999 0 = no delay, immediate response	0.000
F05.066	Login 2 On Delay (see Login 1 On Delay)	0.000 ... 9.999	0.000
F05.067	Login 2 Off Delay (see Login 1 Off Delay)	0.000 ... 9.999	0.000
F05.068	Login 3 On Delay (see Login 1 On Delay)	0.000 ... 9.999	0.000
F05.069	Login 3 Off Delay (see Login 1 Off Delay)	0.000 ... 9.999	0.000
F05.070	Login 4 On Delay (see Login 1 On Delay)	0.000 ... 9.999	0.000
F05.071	Login 4 Off Delay (see Login 1 Off Delay)	0.000 ... 9.999	0.000
F05.072	Login 5 On Delay (see Login 1 On Delay)	0.000 ... 9.999	0.000
F05.073	Login 5 Off Delay (see Login 1 Off Delay)	0.000 ... 9.999	0.000
F05.074	Login 6 On Delay (see Login 1 On Delay)	0.000 ... 9.999	0.000
F05.075	Login 6 Off Delay (see Login 1 Off Delay)	0.000 ... 9.999	0.000

6.2.6. Encoder 1 Settings

F06		Range	Default
F06.076	Factor Counter 1 * Impulse scaling factor for encoder 1	0.00001 ... 9.99999	1.00000
F06.077	Multi. Counter 1 * Multiple impulse count of every impulse	1 ... 99	1
F06.078	DP Counter 1 Decimal point position when displaying the counter value of encoder 1 (see also chapter 7.)	0 ... 5	0
F06.079	Dir Window Counter 1 In order to achieve a stable indication of the actual direction of rotation even under vibration and mechanical oscillation, this parameter provides setting of an impulse window. Before detecting a direction or changing the direction signal, the unit must receive a consecutive number of impulses in the corresponding direction.	1 ... 99	4

*) Affects the position and differential counters only, but not the speed measurement

**) Affects the speed measurement only, but not the position or differential counters

F06		Range	Default
F06.080	Multi. Speed 1 **)	0 ... 999 999	1
F06.081	Divi. Speed 1 **)	0 ... 999 999	1
F06.082	Offset Speed 1 **)	-99 999 ... 99 999	0
	Parameters F06.080 to F06.082 are used to scale the frequency of encoder 1 (XXXXX.X Hz) to customer units. $DisplayValue = \frac{Frequency1 \times F06.080}{F06.081} + F06.082$		
F06.083	DP Speed 1 Decimal point position when displaying the speed value of encoder 1 (see also chapter 7.)	0 ... 5	0
F06.084	Sampling Time 1 **) Minimum time base to sample the input frequency of encoder 1 (sec.)	0.001 ... 9.999	0.010
F06.085	Wait Time 1 **) Time to wait before unit detects zero speed (sec.) Impulse distances greater than this time will result in zero speed detection (standstill)	0.001 ... 9.999	0.100
F06.086	Filter 1 **) Digital Filter for smoothing unstable frequencies (see clarification in chapter 7.3)	0 ... 4	0
	0= Filter OFF (no smoothing) 1= Floating average of the 2 latest results 2= Floating average of the 4 latest results 3= Floating average of the 8 latest results 4= Floating average of the 16 latest results 5= Exponential Filter, T (63%) = 2 x Sampling Time 6= Exponential Filter, T (63%) = 4 x Sampling Time 7= Exponential Filter, T (63%) = 8 x Sampling Time 8= Exponential Filter, T (63%) = 16 x Sampling Time	0 - 8	0
F06.087	Encoder Properties 1 ***)	0 ... 1	1
	0= Differential signals A, /A, B, /B (2 x 90°)		
	1= Single-ended signals A, B (2 x 90°)		
F06.088	Edge Counting 1 *)	0 ... 2	0
	0= Simple (x1)		
	1= Double (x2)		
	2= Full quadrature (x4)		
F06.089	Counting Direction 1 *)	0 ... 1	0
	0= Up when A leads B		
	1= Down when A leads B		

*) Affects the position and differential counters only, but not the speed measurement

**) Affects the speed measurement only, but not the position or differential counters

***) Differential inputs will accept TTL levels and HTL levels (10 - 30 volts) as well.
Single-ended inputs however require HTL level (10 - 30 volts) at any time

6.2.7. Encoder 2 Settings (Description see "Encoder 1 Settings")

F07		Range	Default
F07.091	Factor Counter 2	0.00001 ... 9.99999	1.00000
F07.092	Multi. Counter 2	1 ... 99	1
F07.093	DP Counter 2	0 ... 5	0
F07.094	Dir Window Counter 2	1 ... 99	4
F07.095	Multi. Speed 2	0 ... 999 999	1
F07.096	Divi. Speed 2	0 ... 999 999	1
F07.097	Offset Speed 2	-99 999 ... 99 999	0
F07.098	DP Speed 2	0 ... 5	0
F07.099	Sampling Time 2	0.001 ... 9.999	0.010
F07.100	Wait Time 2	0.001 ... 9.999	0.100
F07.101	Filter 2	0 ... 8	0
F07.102	Encoder Properties 2	0 ... 1	1
F07.103	Edge Counting 2	0 ... 2	0
F07.104	Counting Direction 2	0 ... 1	0

6.2.8. Key command assignments

F08		Range	Default
F08.106	Key UP Action	0 ... 11	0
	0= No function		
	1= Reset counter 1 (encoder 1)		
	2= Reset counter 2 (encoder 2)		
	3= Reset difference [counter1 - counter2]		
	4= Scroll Display		
	5= n. a.		
	6= n. a.		
	7= Store EEPROM		
	8= Release Function Lock (reset output latch)		
	9= Freeze Function		
10= Reset all counters (counter 1, counter 2, difference)			
11= Initialize an automatic self-testing cycle			
F08.107	Key Down Action	0 ... 11	0
	See key „UP“		
F08.108	Key Enter Action	0 ... 11	0
	See key „UP“		

For more details about these functions see section 7.

n.a. = not applicable

6.2.9. Characteristics and functions of the Control Inputs

F08		Range	Default	
F08.109	Input 1 Configuration		0 ... 7	0
	0=	NPN (switch to -), function active LOW		
	1=	NPN (switch to -), function active HIGH		
	2=	NPN (switch to -), rising edge		
	3=	NPN (switch to -), falling edge		
	4=	PNP (switch to +), function active LOW		
	5=	PNP (switch to +), function active HIGH		
	6=	PNP (switch to +), rising edge		
7=	PNP (switch to +), falling edge			
F08.110	Input 1 Action		0 ... 11	0
	0=	No function		
	1=	Reset counter 1 (encoder 1)		
	2=	Reset counter 2 (encoder 2)		
	3=	Reset difference [counter1 - counter2]		
	4=	Scroll Display		
	5=	n. a.		
	6=	Keyboard Disable		
	7=	Store EEPROM		
	8=	Release Function Lock (reset output latch)		
	9=	Freeze Function		
	10=	Reset all counters (counter 1, counter 2, difference)		
11=	Initialize an automatic self-testing cycle			
			For more details about these functions see section 7.	
F08.111	Input 2 Configuration		See „Input 1“ (F08.109)	
F08.112	Input 2 Action		See „Input 1“ (F08.110)	
F08.113	Input 3 Configuration		See „Input 1“ (F08.109)	
F08.114	Input 3 Action		See „Input 1“ (F08.110)	
F08.115	Input 4 Configuration		0 – 3	
	0=	NPN (switch to -) function active LOW	 <p>no edge-triggered functions are possible with Input 4</p>	
	1=	NPN (switch to -) function active HIGH		
	2=	PNP (switch to +), function active LOW		
	3=	PNP (switch to +), function active HIGH		
F08.116	Input 4 Action		See „Input 1“ (F08.110)	

n.a. = not applicable



Unconnected NPN inputs are always HIGH (internal pull-up resistor)

Unconnected PNP inputs are always LOW (internal pull-down resistor)

F08		Range	Default
F08.117	Target Function 1 Output assignment for Function 1	0 ... 255 *)	1+16=17
F08.118	Target Function 2 Output assignment for Function 2	1 => Relay 1	2+32=34
F08.119	Target Function 3 Output assignment for Function 3	2 => Relay 2	4+64=68
F08.120	Target Function 4 Output assignment for Function 4	4 => Relay 3	8+128=136
F08.121	Target Status 1 Output assignment for Status 1	8 => Relay 4	0
F08.122	Target Status 2 Output assignment for Status 2	16 => Output 1	0
F08.123	Target Status 3 Output assignment for Status 3	32 => Output 2	0
F08.124	Target Status 4 Output assignment for Status 4	64 => Output 3	0
		128 => Output 4	0



*) Setting via 8-bit binary code (see also chapter 3.4).

It is possible to assign several outputs to one function.

It is also possible to assign several functions to the same output.

Conflicting and incompatible settings must however be avoided.

The default settings shown above mean:

Function 1 operates Relay 1 and Output 1

Function 2 operates Relay 1 and Output 2

Function 3 operates Relay 1 and Output 3

Function 4 operates Relay 1 and Output 4

No outputs are assigned to the status signals by default.

F08		Range	Default
F08.125	Target Display (see clarification under 7.7) Presentation of actual switching events on the LED display	0 ... 15	0
	0= no display	4-bit binary code: 1 => Function 1 2 => Function 2 4 => Function 3 8 => Function 4	
	1= Display when Switching Function 1 is true		
	2= Display when Switching Function 2 is true		
	3= Display when Functions 1 and 2 are true		
	4= Display when Switching Function 3 is true		
	8= Display when Switching Function 4 is true		
	15= Display when all Switching Functions are true		
F08.126	Release Action (Release Latch of Functions) Parameter to define which of the functions should be released from Latch state by external command	0 ... 15	0
	0= no Function	4-bit binary code: 1 => Function 1 2 => Function 2 4 => Function 3 8 => Function 4	
	1= Release Latch of Function 1		
	2= Release Latch of Function 2		
	3= Release Latch of Function 1 and Function 2		
	4= Release Latch of Function 3		
	8= Release Latch of Function 4		
	15= Release Latch of all Functions		
F08.127	Freeze Action Parameter to define which of the functions should be frozen upon external command	0 ... 15	0
	0= no Function	4-bit binary code: 1 => Function 1 2 => Function 2 4 => Function 3 8 => Function 4	
	1= Freeze Function 1		
	2= Freeze Function 2		
	3= Freeze Function 1 and Function 2		
	4= Freeze Function 3		
	8= Freeze Function 4		
	15= Freeze all Functions		
F08.128	Output Error Configuration Parameter to blank out unused switching outputs in order to avoid continuous "wire break" error messages	0 ... 15	0
	0= all outputs are connected and in use	4-bit binary code: 1 => Function 1 2 => Function 2 4 => Function 3 8 => Function 4	
	1= Output Out 1s is unused		
	2= Output Out 2s is unused		
	3= Outputs Out 1s and Out 2s are unused		
	4= Output Out 3s is unused		
	8= Output Out 4s is unused		
	15= all outputs are unconnected and out of use		

6.2.10. Serial communication settings

F09		Range	Default
F09.132	Unit Number	11 ... 99	11
F09.133	Serial Baud Rate	0 ... 6	0
	0= 9600 Baud		
	1= 4800 Baud		
	2= 2400 Baud		
	3= 1200 Baud		
	4= 600 Baud		
	5= 19200 Baud		
	6= 38400 Baud		
F09.134	Serial Format	0 ... 9	0
	0= 7 Data, Parity even, 1 Stop		
	1= 7 Data, Parity even, 2 Stop		
	2= 7 Data, Parity odd, 1 Stop		
	3= 7 Data, Parity odd, 2 Stop		
	4= 7 Data, no Parity, 1 Stop		
	5= 7 Data, no Parity, 2 Stop		
	6= 8 Data, Parity even, 1 Stop		
	7= 8 Data, Parity odd, 1 Stop		
	8= 8 Data, no Parity, 1 Stop		
	9= 8 Data, no Parity, 2 Stop		

6.2.11. Special Functions

F10		Range	Default	
F10.138	Input filter: must be set to "0".	0 ... 3	0	
F10.139	Trigger Threshold 1 for encoder1 inputs *)	30 ... 250	166	
F10.140	Trigger Threshold 2 for encoder2 inputs *)	30 ... 250	166	
F10.141	Brightness of the 7-segment LED display	0 ... 4	0	
	0=			100% of maximum brightness
	1=			80% of maximum brightness
	2=			60% of maximum brightness
	3=			40% of maximum brightness
	4=			20% of maximum brightness
F10.142	Display Time: Update time (sec.) for display only	0.005 ... 9.999	0.050	
F10.143	Frequency Control must be set to "0"	0 ... 1	0	
F10.144	Power Down (date retention of actual counter values in case of power-down)	0 ... 1	0	
	0=			No retention of positional and differential counters, Restart with zero upon power-up
	1=			Actual values of positional and differential counters are retained after power-down
F10.145	Target Display Break Time Programmable time to momentary interrupt a forced indication of switching states for temporary display of other values	0 ... 99 sec.	0	
F10.146	Start Display Defines the display value after the power-on see table (page 39) Command Scroll Display/LED Display Value	0 – 8	0	

*) Must be set to the default value (166) for any kind of input signals, except for single-ended TTL signals which require a setting of 35.

6.2.12. Keypad protection codes

F11		Range	Default
F11.147	Protect group F01	0 = no protection	0
F11.148	Protect group F02		0
F11.149	Protect group F03		0
-	-	1 – 999 999 = Protection code for the actual parameter group	-
F11.155	Protect group F09		0
F11.156	Protect group F10		6078
F11.157	Protect group F11		6078



Since some parameters of parameter group 10 are not for customer use, and in order to avoid accidental change of these settings, menu F10 and the Password menu itself have been protected by default (default password "6078")

7. Important Hints for the User

7.1. Description of keypad commands and remote commands

No.	Command	Description	Assignment to					
			Keypad	Input				
0	Do nothing	No commands are assigned to keypad and inputs						
1	Reset Counter 1	Sets the internal position counter for encoder 1 to zero. (does not effect the differential counter)	yes	yes				
2	Reset Counter 2	Sets the internal position counter for encoder 2 to zero. (does not effect the differential counter)	yes	yes				
3	Reset Difference	Sets the internal differential counter to zero. (does not affect counter 1 and counter 2)	yes	yes				
4	Scroll Display	Selects the source of the digital display. The front LEDs L1 and L2 indicate what the actual reading is	yes	yes				
					No.	LED Display Value	L1	L2
					0	Display OFF (only two decimal points are lit)	OFF	OFF
					1	Actual Position Encoder 1	ON	OFF
					2	Actual Position Encoder 2	OFF	ON
					3	Actual Speed Encoder 1 (custom scaling)	blink	OFF
					4	Actual Speed Encoder 2 (custom scaling)	OFF	blink
					5	Actual Differential Counter	ON	ON
					6	Actual Differential Counter (bar graph display, see diagram)	blink	blink
					7	Error Indication (see 7.6 for details)	OFF	OFF
8	Display of the state of Switching Functions (see 7.7 for details)	OFF	OFF					

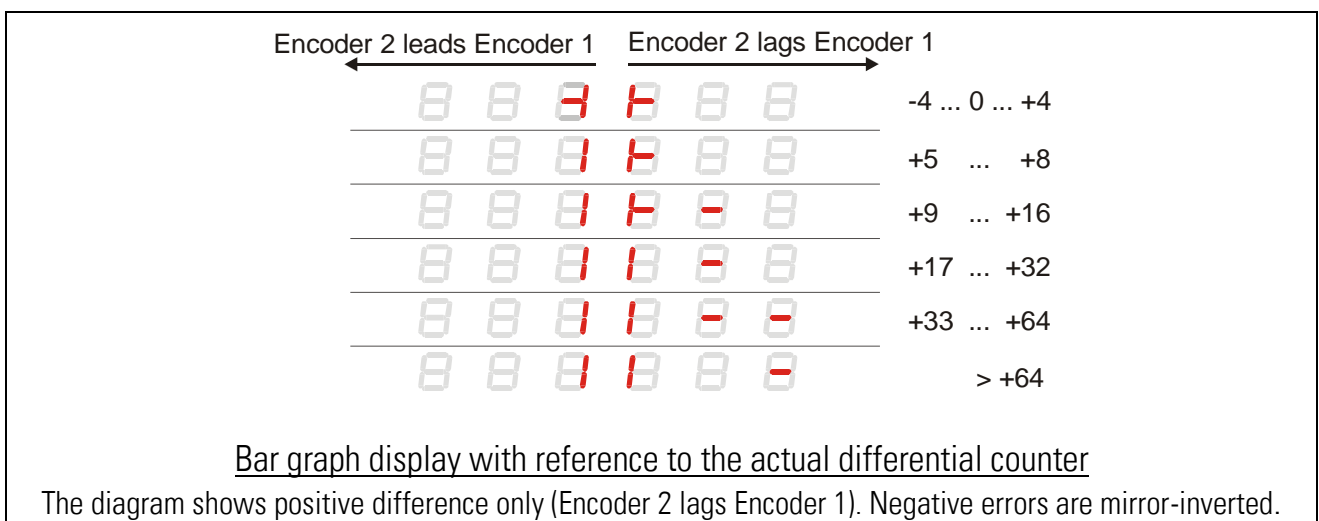

No.	Command	Description	Assignment to	
			Keypad	Input
5	n.a.			
6	Parameter Disable	Disables the keypad for any access to parameters. Commands assigned to the keypads will remain executable	no	yes
7	Store EEPROM	Stores actual operational settings to the EEPROM, so they remain available also after power down.	yes	yes
8	Release Function Lock	Releases all switching functions defined by parameter F08.126 from their latch state	yes	yes
9	Freeze Function *)	Freezes all functions defined by parameter F08.127 to their actual switching state	yes	yes

n.a. = not applicable



*) After a power-down situation the "Freeze" function will operate as follows:

- a. If upon power recurrence the external freeze input is still active, all selected Functions will return with their previous (frozen) state
- b. If upon power recurrence the external freeze command is no more active, the "Freeze" state will be canceled and all functions will continue to follow the actual process state.
- c. During power-up of the unit, for a short period of about 1 sec all outputs may temporary take an undefined switching state (initialization phase)

7.2. Hints for Scaling of the Unit

The scaling parameters of the unit will affect the **display of the actual values** as well as the associated **Setpoints for the switching functions**. In principle, there are two fully independent sets of scaling parameters:

- a. Scaling parameters for frequencies and speeds
- b. Scaling parameters for counters, positions and differential positions



Where your application uses setpoints for control of speeds, you have to use the speed dimensions according to the scaling of the corresponding encoder to set your speeds

Where your application uses positional or differential counter setpoints for control of distances or errors, you have to use the length dimensions according to the scaling of the corresponding encoder to set your positions

7.2.1. Speed Scaling

Internally the unit measures all speed-related values as a frequency with a resolution of 0.1 Hz. This numeric value is used as a basis for all further calculations.

When e.g. the actual frequency of an encoder is 1.5 kHz, the unit would internally use a value of 15 000.

You are free to attach any other dimensions to your speed measurements (e.g. RPM, m/min, miles/h etc.) by corresponding setting of the parameters F06.080 to F06.082 (encoder 1) or parameters F07.095 to F07.097 (encoder 2)

Example: a frequency of 1.5 kHz on encoder input 1 should be converted to a speed scaling of 67.0 m/min. This means the internal value of „15 000“ needs to be converted to a value of „670“ (display of 67.0 requires a result of 670 which appears as 67.0 when the decimal point is switched on).

It is easy to understand that we only need to divide the basic frequency value by 15000, then multiply it again by 670 (F06.80 = 670 and F06.81 = 15 000). The Offset (F06.82) remains set to 0 (because frequency = 0 means at the same time speed = 0).

$$\text{Speed [1/10 m/min]} = f \text{ [1/10 Hz]} \times \frac{\boxed{670} \leftarrow (\text{F06.80})}{\boxed{15\ 000} \leftarrow (\text{F06.81})}$$

After setting the decimal point (F06.83 = 1), the speed display and all Set Speeds related to encoder 1 are set to a format xxx.x m/min (Set Speed 1.1 and Set Speed 1.2 of all Switching Functions). This speed scaling will not affect the speeds of encoder 2 nor the position counters or differential counters of the unit.

7.2.2. Standstill Definition (Wait-Time)

This definition is related to the input frequency only and does not depend on any other scaling parameters. It is necessary to set the period time of the minimum frequency that the unit still should consider as "motion".

When e.g. we set „Wait Time1“ to 0.1 sec., the unit will declare all encoder1 frequencies higher than 10 Hz for "Motion" and all frequencies lower than 10 Hz for "Standstill".

7.2.3. Scaling of the Position Counters for Direct Impulse Counting

When you like the counters (Counter 1 and Counter 2) to count just the encoder increments without any scaling, please set the associated impulse scaling factors (F06.76 respectively F07.091) to 1,00000, and set the associated impulse multiplier (F06.077 respectively F07.092) to „1“. All positional and differential counts as well as the attached setpoints (Setpoint Position und Differential Setpoint) will then be straight incremental.*)

7.2.4. Differential evaluation

When the two encoders provide different ppr numbers, or when a gearbox is installed between encoder1 and encoder2, any differential evaluation requires adaptation of both encoders by proper scaling. **)

You must know the accurate number of impulses generated by both encoders in one cycle or on a defined distance (e.g. one full revolution of the slower encoder or a traveling distance of 1000 mm or similar) Following formula applies for the differential encoder display:

$$\text{Difference} = [\text{Counter of encoder 1}] \times [\text{Factor Counter1}] - [\text{Counter of encoder 2}] \times [\text{Factor Counter2}]$$

In case of synchronous motion of both encoders it is therefore necessary to conform to the following condition in order to achieve zero difference:

$$[\text{Counter of encoder 1}] \times [\text{Factor Counter1}] = [\text{Counter of encoder 2}] \times [\text{Factor Counter2}]$$

A simple solution exists by using the figures of the impulse count on one side as a factor setting on the other side. If e.g. in a defined cycle encoder1 would generate 20 000 impulses while encoder2 would generate only 300 impulses, use 0.03000 for the Factor Counter1 and 2.00000 for the Factor Counter2. For precision applications it may be important to avoid cumulating errors caused by ratios with more than 5 decimal positions.

7.2.5. Scaling to customer engineering units

The parameters „Factor Counter“ and „Multi Counter“ are used the same way for scaling of the position counters to customer units. If e.g. you like to receive a 0.1 mm scaling with an existing resolution of 20 000 increments per meter, just set the corresponding factor to 0.50000 (20 000 x 0.5 = 10 000, which appears as 1000.0 mm when you switch the decimal point on)

*) under consideration of the selected edge-counting mode (F06.088 respectively F07.103)

**) only important for differential evaluations (encoder 1 – encoder 2)

7.3. Example for the Function of the Digital Filter

Filter settings are intended to have an effect on speed measurement only but not on the positional counting. The diagrams below explain the response of the monitor with different filter settings. In our example the following initial situation is assumed:

- Parameter "Sampling Time" is set to 10 msec
- The input frequency would jump from the actual speed value to a higher speed value for a transition period of 60 msec. (e.g. by mechanical disturbance), and after this turn back to the previous speed value
- The drawings show the speed evaluation behind the filter with filter settings 0, 1, 3 and 5 *)

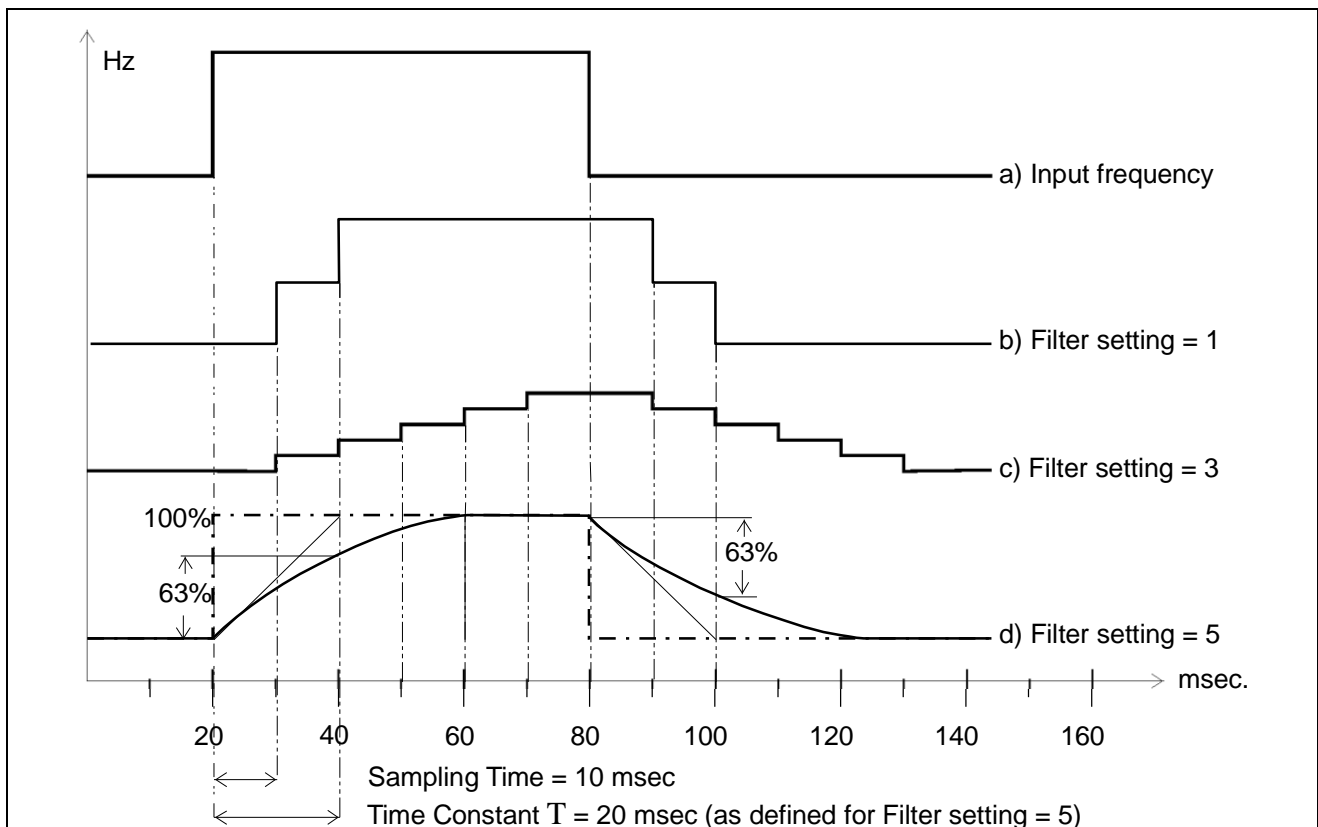

- a) Jump of the input frequency (no filtering)
- b) Filter = 1: the unit continuously forms the floating average of the latest two measuring cycles, Therefore, after the first sampling period the response is 50% of the total jump only, and after the second sampling period the jump will reach the full jumping amplitude.
- c) Filter = 3: the unit continuously forms the floating average of the latest eight measuring cycles, Therefore, after the first sampling period the response is 12.5% of the total jump only, and after seven sampling periods more the jump would reach the full jumping amplitude. However, since the whole duration of the jump takes 6 sampling periods only, the full jumping amplitude will not be reached.
- d) Filter = 5: the unit uses an exponential filtering curve. According to parameter definition, filter setting = 5 is based on a Time Constant of $T = 2 \times \text{Sampling Time}$. This means we reach the 63% threshold of the full jumping amplitude after a time of $2 \times 10 = 20$ msec.



















*) The course of both frequencies (before and after filtering) can be visualized on top of each other by using the oscilloscope function of the OS32 operator software (see menu "Tools"). Please also refer to section "Actual Measuring Values" on page 53.

7.4. Internal Self-Testing Functions of the Monitor

The MS 640 monitor is equipped with comprehensive and profound self-testing routines in order to ensure a maximum of functional safety and reliability of the whole control process. These tests provide at an early stage detection and immediate indication of possible failures inside the monitor itself.

The following three different types of testing routines are available:

	Cyclic background tests : These test run always and continuously in the background of the unit (cycle time < 1 msec)
	Initialization Tests upon power up: These tests are triggered automatically every time the power of the unit is switched on
	Manual Tests: These tests can be triggered at any time by external operator command (see 7.5)

Failure event to be detected	Test
Internal supply voltage fault: One or several of the following internal voltages are out of the permitted tolerance range: +5V, +12V, -12V, aux. voltage outputs for encoder supplies +5,2V or +24V	
Temperature fault: The internal temperature of the monitor exceeds the permitted range, so that a faultless operation of all components can no more be guaranteed.	
Failure of relays or switching outputs The feedback signal of a relay or a transistor output is not coincident with the internal control state, or one of the transistor outputs indicates short-circuit or overload or cable break	 
CRC Error A fault has been detected with the consistency of the firmware of the unit, and a proper flow of the internal control programs can potentially no more be guaranteed	 
Flash Data Error (Parameters) The value of one of the parameters is not coincident with the inverted mirror of the same parameter which has been stored as a copy in a different location of the Flash memory	 
RAM Error A defective bit or a suspicious address line have been detected in the RAM memory	 
Default Parameter Set The unit did not receive yet proper operating parameters which are suitable for an application, or all parameters have been reset to their default values, i.e. the monitor is not ready to work	 
Logical Input Error The processor reading of a logical input is different from the expected result according to the testing signal which the processor sends to the input	
Control Input Error The processor reading of a control input is different from the expected result according to the testing signal which the processor sends to the input	



Subsequently the 7-segment display will be used for indication of hexadecimal characters. The hex values 0 – 9 and A, B, C, D, E, F are presented on the display as shown in the table

0000	0001	0010	0011	0100	0101	0110	0111	1000	1001	1010	1011	1100	1101	1110	1111
0	1	2	3	4	5	6	7	8	9	A	b	C	d	E	F

7.5. Manual Release of a Self-Testing Cycle

At any time the operator can release a complete self test by means of a corresponding manual command (see assignments of commands to keys and inputs, chapters 6.2.8 and 6.2.9).

	<ul style="list-style-type: none"> • Every manually released testing cycle will also commutate all relays and outputs to both directions. The operator has to make sure that such contact and output actions will not result in undesirable implications on the machinery. • While running the manual test all of the 4 control inputs must be open or in a high-impedance state. Where one of the inputs is connected to GND (Low) or +24V (HIGH) by low impedance, the corresponding input will be declared as "faulty" • While running the manual test all of the 6 logical inputs must be open or in LOW state. Where one of the inputs is connected to +24V (HIGH) by low impedance, the corresponding input will be declared as "faulty"
---	---









This is the sequence of a testing cycle in detail:

No.	Display	Clarification
01	SELF	A testing cycle has been released: "SELF" is blinking for about 5 seconds
02	rEL	Relay-Test: Display "rEL" followed by 1 - 2 - 3 - 4. All 4 relays will switch in both directions and the feedback of the contact positions will be verified
03	Out	Output Test: Display "Out" followed by 1 - 2 - 3 - 4. Out1(s) to Out4(s) will switch in both directions and the feedback signal will be checked for correct switching level and for wire break, short circuit and overload
04	LoGin	Logical Input Test: Display "LoGin" followed by 1 - 2 - 3 - 4 - 5 - 6. All inputs will be automatically connected to LOW and HIGH potential with verification of correct reading by the processor
05	Con_In	Control Input Test: Display "Con_In" followed by 1 - 2 - 3 - 4. All inputs will be automatically connected to LOW and HIGH potential with verification of correct reading by the processor
06	FLASH	Flash Memory Test (Parameters): all memory contents will be compared and verified with the inverted safety copy of parameters deposited on another location of the memory
07	CRc	CRC Test (Firmware Consistency): this test uses a most approved polynomial verification method to approve the correctness of every single step of the program course
08	rAni	RAM Test: the entire Random Access Memory will be checked for correct operation, bit by bit (testing method "walking one")
09	E_0000	End of Test: Display E_0000 indicates that no error could be detected. In all other cases a corresponding error code appears in display (see 7.6)
10	Normal Display	Automatic Re-Initialization: in a time of about 3 seconds the unit executes a new starting cycle (similar to power up) and then returns to normal control operation

7.6. Behavior in Case of Error, Error Messages

Every detected error will immediately switch the Ready signal off. At the same time an error message is indicated on the LED display and an error status word is sent to the corresponding memory location (serial access code **8 A**).

Error messages use binary coded information which are displayed as hexadecimal characters.

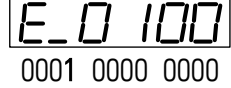
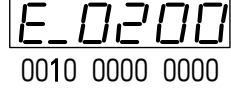
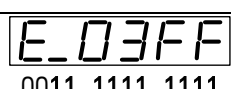
 0000 0000 0001	Parameter Error (binary 1): the unit did not receive yet operational parameters, or the parameters have been reset to their default values
 0000 0000 0010	Internal Voltage Error (binary 2): one of the following internal voltages is out of the permitted tolerance range: +5V, +12V, -12V, aux. voltage outputs +5,2V or +24V
 0000 0000 0100	Temperature Error (binary 4): the internal temperature exceeds the permitted range, so that a faultless operation of all components can no more be guaranteed
 0000 0000 1000	CRC-Fehler (binary 8): a fault has been detected with the consistency of the firmware, a proper program flow can potentially no more be guaranteed
 0000 0001 0000	Flash Memory Error (binary 16): the value of a parameters is not coincident with its inverted safety copy stored in a different location of the Flash memory
 0000 0010 0000	RAM Error (binary 32): a defective bit or a suspicious address line have been detected in the Random Access Memory
 0000 0100 0000	Relay Error (binary 64): the feedback signal of a relay contact is not coincident with the internal excitation of the coil
 0000 1000 0000	Output Error (binary 128): the feedback signal of transistor output is not coincident with the internal state, or short-circuit, overload or cable break has been detected
 0001 0000 0000	Logical Input Error (binary 256): the processor reading of a logical input is different from the expected result according to the testing signal sent to the input
 0010 0000 0000	Control Input Error (binary 512) : the processor reading of a control input is different from the expected result according to the testing signal sent to the input
 0011 1111 1111	Error Indication Example: if all errors were present at the same time, the unit would indicate the error code beside (equals to decimal 1023)



- Error messages operate with the highest priority in display and will overwrite all other display values right away
- Chapter 7.8 explains how to temporary blank out the error messages in order to be able to check for other measuring values (e.g. for analysis of the actual error)

7.7. Display of Switching Functions and Principle of Operation of Parameter "Target Display"

Many times it may be useful to see the actual state of the switching matrix on the display (cf. 3.4 and 4.3).

When the scrolling function of the display has been enabled, it is possible at any time to scroll to the corresponding switching state indication (see "Scroll Display" in chapter 7.1).

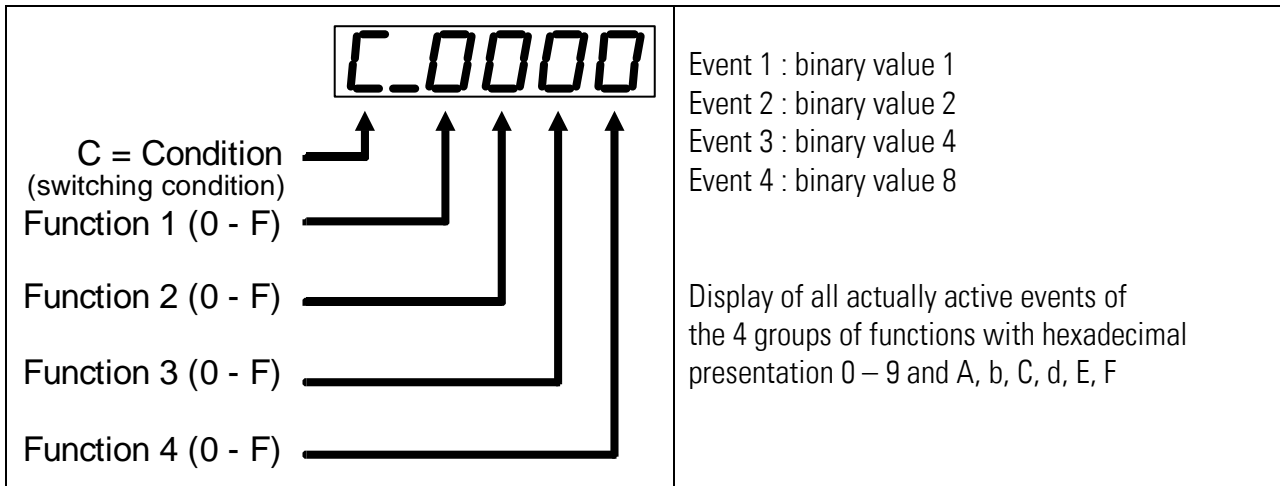

Furthermore, parameter "Target Display" allows setting for automatic change-over to the display of switching states upon occurrence of certain events (visual alert).

Parameter "Target Display" (F08.125) defines the function which - if true - will activate the visual alert and overwrite the normal display by indicating actual switching functions. When e.g. this parameter has been set to "12", the display will automatically change over if one of the functions 3 or 4 becomes true ($4 + 8 = 12$).

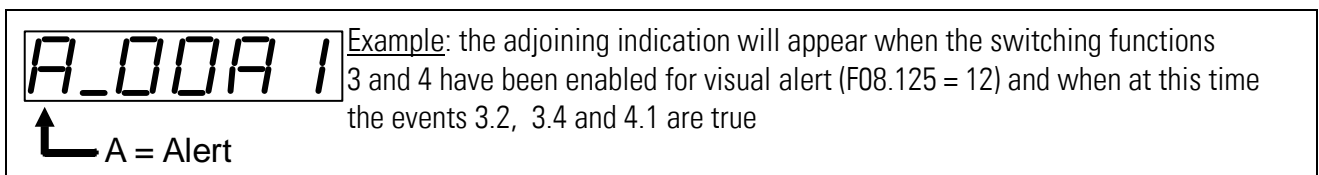

- Once a visual alert has been triggered, the display of actual events will immediately be frozen. Later changes of events and switching functions will no more change the display
- The hexadecimal code of actual events remains frozen and stored, even after the power-of the unit has been switched off and on again
- The display of switching conditions and events always has the highest priority against other display values. However, a temporary change over to other display values is possible (cf. 7.8)
- The only option to reset the system to normal display is by remote operator command "Release Function Lock" (cf. 6.2.8 and 6.2.9 and parameter F08.126 "Release Action")

7.8. Temporary Interruption of the Display of Switching States

Whenever parameter "Target Display" causes overwriting of the actual display, or when an **Error Message** appears, the normal scrolling of the display values according to chapter 7.1 will be disabled until the event of higher priority has disappeared. Where you still like to get access to other actual display values (e.g. to find out the reason for an error) you must set the parameter "Target Display Break" correspondingly. When e.g. this parameter has been set to 10 seconds, the unit will accept a corresponding time window for scrolling the display to other values, before it will force again the display message with the highest priority.

7.9. Operation of the Watchdog Function

As soon as the unit has been switched on and passed the initialization routine, all further courses of the program are subject to a continuous watchdog supervision. In case that the program cycle should not pass all internal checkpoints in the right sequence and the within the scheduled time, the watchdog will force an immediate re-initialization of the unit (maximum delay time = 170 msec). All behavior after this is equal to a new start after power down.

7.10. Behavior of the Monitor after Power up

After switching the power supply on, all monitor functions will first be disabled.

All relays and outputs are in their OFF state and all status signals are LOW (Ready included).

After internal initialization the unit first executes an automatic self test according to 7.4. This will take about 3 seconds. As soon as the self test has been concluded successfully and without error, the Ready signal will switch on and the unit takes over its control functions.

- When parameter "Power Down" has been set to "0", the counters and the differential counter are automatically reset to zero. Otherwise the counters will come back with their last counting values before powering the unit down
- When the parameters "Lock Function" attached to each switching function have been set to 0 or to 1, the corresponding switching functions will immediately act in accordance with the actual process values of the machine.
- When the parameters "Lock Function" attached to each switching function have been set to 2, the corresponding switching function will come back with its locked switching state, provided the function was already in the latch state before power has been switched off.
- After power-up and successful self-test the unit always displays E_0000 first, to indicate that all conditions and functions are error-free.
- When during the self test an error has been detected, the Ready signal will remain in OFF state and a corresponding error message according to chapter 7.6 will be displayed.

8. Serial Access Codes

Parameters

No.	Menu	Description	Code	Minimum	Maximum	Default
0	F01	Set Speed 1.1	A0	0	999999	11001
1	F01	Set Speed 1.2	A1	0	999999	11002
2	F01	Set Speed 2.1	A2	0	999999	21001
3	F01	Set Speed 2.2	A3	0	999999	21002
4	F01	Setpoint Counter 1	A4	0	999999	31000
5	F01	Setpoint Counter 2	A5	0	999999	41000
6	F01	Differential Setpoint	A6	0	999999	51000
7	F01	Switch Event 1	A7	-2147483648	2147483647	0
8	F01	Switch Event 2	A8	-2147483648	2147483647	0
9	F01	Switch Event 3	A9	-2147483648	2147483647	0
10	F01	Switch Event 4	B0	-2147483648	2147483647	0
11	F01	Switch on Delay	B1	0	9999	0
12	F01	Pulse Time	B2	0	9999	0
13	F01	Lock Function	B3	0	1	0
14	F01	Polarity	B4	0	1	0
15	F01	Reserved	B5	0	999999	0
16	F02	Set Speed 1.1	B6	0	999999	12001
17	F02	Set Speed 1.2	B7	0	999999	12002
18	F02	Set Speed 2.1	B8	0	999999	22001
19	F02	Set Speed 2.2	B9	0	999999	22002
20	F02	Setpoint Counter 1	C0	0	999999	32000
21	F02	Setpoint Counter 2	C1	0	999999	42000
22	F02	Differential Setpoint	C2	0	999999	52000
23	F02	Switch Event 1	C3	-2147483648	2147483647	0
24	F02	Switch Event 2	C4	-2147483648	2147483647	0
25	F02	Switch Event 3	C5	-2147483648	2147483647	0
26	F02	Switch Event 4	C6	-2147483648	2147483647	0
27	F02	Switch on Delay	C7	0	9999	0
28	F02	Pulse Time	C8	0	9999	0
29	F02	Lock Function	C9	0	1	0
30	F02	Polarity	D0	0	1	0
31	F02	Reserved	D1	0	999999	0
32	F03	Set Speed 1.1	D2	0	999999	13000
33	F03	Set Speed 1.2	D3	0	999999	23000
34	F03	Set Speed 2.1	D4	0	999999	13000
35	F03	Set Speed 2.2	D5	0	999999	23000
36	F03	Setpoint Counter 1	D6	0	999999	33000
37	F03	Setpoint Counter 2	D7	0	999999	43000
38	F03	Differential Setpoint	D8	0	999999	53000

Parameters (cont.)

No.	Menu	Description	Code	Minimum	Maximum	Default
39	F03	Switch Event 1	D9	-2147483648	2147483647	0
40	F03	Switch Event 2	E0	-2147483648	2147483647	0
41	F03	Switch Event 3	E1	-2147483648	2147483647	0
42	F03	Switch Event 4	E2	-2147483648	2147483647	0
43	F03	Switch on Delay	E3	0	9999	0
44	F03	Pulse Time	E4	0	9999	0
45	F03	Lock Function	E5	0	1	0
46	F03	Polarity	E6	0	1	0
47	F03	Reserved	E7	0	999999	0
48	F04	Set Speed 1.1	E8	0	999999	14000
49	F04	Set Speed 1.2	E9	0	999999	24000
50	F04	Set Speed 2.1	F0	0	999999	14000
51	F04	Set Speed 2.2	F1	0	999999	24000
52	F04	Setpoint Counter 1	F2	0	999999	34000
53	F04	Setpoint Counter 2	F3	0	999999	44000
54	F04	Differential Setpoint	F4	0	999999	54000
55	F04	Switch Event 1	F5	-2147483648	2147483647	0
56	F04	Switch Event 2	F6	-2147483648	2147483647	0
57	F04	Switch Event 3	F7	-2147483648	2147483647	0
58	F04	Switch Event 4	F8	-2147483648	2147483647	0
59	F04	Switch on Delay	F9	0	9999	0
60	F04	Pulse Time	G0	0	9999	0
61	F04	Lock Function	G1	0	1	0
62	F04	Polarity	G2	0	1	0
63	F04	Reserved	G3	0	999999	0
64	F05	Login 1 On Delay	G4	0	9999	0
65	F05	Login 1 Off Delay	G5	0	9999	0
66	F05	Login 2 On Delay	G6	0	9999	0
67	F05	Login 2 Off Delay	G7	0	9999	0
68	F05	Login 3 On Delay	G8	0	9999	0
69	F05	Login 3 Off Delay	G9	0	9999	0
70	F05	Login 4 On Delay	H0	0	9999	0
71	F05	Login 4 Off Delay	H1	0	9999	0
72	F05	Login 5 On Delay	H2	0	9999	0
73	F05	Login 5 Off Delay	H3	0	9999	0
74	F05	Login 6 On Delay	H4	0	9999	0
75	F05	Login 6 Off Delay	H5	0	9999	0

Parameters (cont.)

No.	Menu	Description	Code	Minimum	Maximum	Default
76	F06	Factor Counter 1	00	1	999999	100000
77	F06	Multi. Counter 1	01	1	99	1
78	F06	DP Counter 1	02	0	5	0
79	F06	Dir Window Counter 1	03	1	99	4
80	F06	Multi. Speed 1	04	1	999999	1
81	F06	Divi. Speed 1	05	1	999999	1
82	F06	Offset Speed 1	06	-99999	99999	0
83	F06	DP Speed 1	07	0	5	0
84	F06	Sampling Time 1	08	1	9999	10
85	F06	Wait Time 1	09	1	9999	100
86	F06	Filter 1	10	0	7	0
87	F06	Encoder Properties 1	11	0	3	1
88	F06	Edge Counting 1	12	0	2	0
89	F06	Counting Direction 1	13	0	1	0
90	F06	Reserved	14	0	999999	0
91	F07	Factor Counter 2	15	1	999999	100000
92	F07	Multi. Counter 2	16	1	99	1
93	F07	DP Counter 2	17	0	5	0
94	F07	Dir Window Counter 2	18	1	99	4
95	F07	Multi. Speed 2	19	1	999999	1
96	F07	Divi. Speed 2	20	1	999999	1
97	F07	Offset Speed 2	21	-99999	99999	0
98	F07	DP Speed 2	22	0	5	0
99	F07	Sampling Time 2	23	1	9999	10
100	F07	Wait Time 2	24	1	9999	100
101	F07	Filter 2	25	0	7	0
102	F07	Encoder Properties 2	26	0	3	1
103	F07	Edge Counting 2	27	0	2	0
104	F07	Counting Direction 2	28	0	1	0
105	F07	Reserved	29	0	999999	0
106	F08	Key Up Action	30	0	16	0
107	F08	Key Down Action	31	0	16	0
108	F08	Key Enter Action	32	0	16	0
109	F08	Input 1 Configuration	33	0	7	0
110	F08	Input 1 Action	34	0	16	0
111	F08	Input 2 Configuration	35	0	7	0
112	F08	Input 2 Action	36	0	16	0
113	F08	Input 3 Configuration	37	0	7	0
114	F08	Input 3 Action	38	0	16	0
115	F08	Input 4 Configuration	39	0	3	0
116	F08	Input 4 Action	40	0	16	0

Parameters (cont.)

No.	Menu	Description	Code	Minimum	Maximum	Default
117	F08	Target Function 1	41	0	255	17
118	F08	Target Function 2	42	0	255	34
119	F08	Target Function 3	43	0	255	68
120	F08	Target Function 4	44	0	255	136
121	F08	Target Status 1	45	0	255	0
122	F08	Target Status 2	46	0	255	0
123	F08	Target Status 3 (keypad)	47	0	255	0
124	F08	Target Status 4 (READY)	48	0	255	0
125	F08	Target Display	49	0	15	0
126	F08	Release Action	50	0	15	0
127	F08	Freeze Action	51	0	15	0
128	F08	Output Error Config.	52	0	15	0
129	F09	Unit Number	90	11	99	11
130	F09	Serial Baud Rate	91	0	6	0
131	F09	Serial Format	92	0	9	0
132	F09	Reserved	I0	0	999999	0
133	F09	Reserved	I1	0	999999	0
134	F09	Reserved	I2	0	999999	0
135	F10	Input Filter	I3	0	3	0
136	F10	Trigger Threshold 1	I4	30	250	166
137	F10	Trigger Threshold 2	I5	30	250	166
138	F10	Brightness	I6	0	4	0
139	F10	Display Time	I7	5	9999	50
140	F10	Frequency Control	I8	0	1	0
141	F10	Power Down Mode	I9	0	1	1
142	F10	Target Display Break	J0	1	99	1
143	F10	Reserved	J1	0	999999	0
144	F11	Protect Group F01	J2	0	999999	0
145	F11	Protect Group F02	J3	0	999999	0
146	F11	Protect Group F03	J4	0	999999	0
147	F11	Protect Group F04	J5	0	999999	0
148	F11	Protect Group F05	J6	0	999999	0
149	F11	Protect Group F06	J7	0	999999	0
150	F11	Protect Group F07	J8	0	999999	0
151	F11	Protect Group F08	J9	0	999999	0
152	F11	Protect Group F09	K0	0	999999	0
153	F11	Protect Group F10	K1	0	999999	6078
154	F11	Protect Group F11	K2	0	999999	6078
155	F11	Reserved	K3	0	999999	0
156	F11	Reserved	K4	0	999999	0
157	F11	Reserved	K5	0	999999	0
158	F11	Reserved	K6	0	999999	0
159	F11	Reserved	K7	0	999999	0

Control Commands

No.	Command	Code	Wert	Serial	Bus	Remote
0	Reset Counter A	60	0080	Yes	No	Yes
1	Reset Counter B	65	0040	Yes	No	Yes
2	Reset Difference	66	0020	Yes	No	Yes
3	Scroll Display	56	0010	Yes	No	Yes
4	Activate Data	67	0008	Yes	No	No
5	Keyboard Disable	57	0004	Yes	No	Yes
6	Store EEPROM	68	0002	Yes	No	Yes
7	Release Function Lock	58	0001	Yes	No	Yes
8	Freeze Function	59	8000	Yes	No	Yes
9	Reset Total	55	4000	Yes	No	Yes
10	Start Self Test	61	2000	Yes	No	Yes

Actual Measuring Values

No.	Description	Code
1	Actual differential position (encoder 1 - encoder 2))	:1
2	Actual frequency of encoder 1 before filtering (Scaling in steps of 0,1 Hz) *)	:2
3	Actual frequency of encoder 2 before filtering (Scaling in steps of 0,1 Hz) *)	:3
4	Actual speed of encoder 1, operator units according to scaling	:4
5	Actual speed of encoder 2, operator units according to scaling	:5
6	Actual position of counter 1 (encoder1)	:6
7	Actual position of counter 2 (encoder2)	:7
8	Actual frequency of encoder 1 after filtering (Scaling in steps of 0,1 Hz) *)	;3
9	Actual frequency of encoder 2 after filtering (Scaling in steps of 0,1 Hz) *)	;4



*) The course of both frequencies (before and after filtering) can be visualized on top of each other by using the oscilloscope function of the OS32 operator software (see menu "Tools"). Please also refer to the description of Filter Functions on page 43.

9. Technical Specifications

AC power supply	:	24 V~ +/-10%, 15 VA
DC power supply	:	24V- (17 – 40V), approx. 100 mA (+ encoders)
Ripple	:	≤ 10% @ 24VDC
Aux. encoder supply outputs:		2 x 5,2 VDC, 150 mA each 2 x 24V DC, 120 mA each
Inputs	:	2 universal encoder inputs, A, /A, B, /B each 4 digital control inputs HTL/PNP-NPN (Ri = 3.3 kΩ) Low < 2.5 V, High > 10 V, min. pulse width 50 μsec. 6 logical inputs HTL / PNP only (Ri = 3.3 kΩ) Low < 2.5 V, High > 10 V
Counting frequency (per encoder)	:	RS422 and TTL differential: 500 kHz HTL single ended: 200 kHz TTL single-ended: 200 kHz
Switching outputs	:	4 fast power transistors 5 - 30V, 350 mA (b) Response time < 1 msec. (a),
Relay outputs	:	4 forced-guided relays (dry changeover) (b) AC switching capability max. 250 V/ 1 A/ 250 VA DC switching capability max. 100 V/ 1A/ 100 W
Serial link	:	RS232 and RS485, 2400 – 38400 Bauds
Ambient temperature	:	Operation: 0 - 50°C (32 – 122°F) Storage: -25 - +70°C (-13 – 158°F)
Housing	:	Norly UL94 – V-0
Display	:	6 Digit, LED, high- efficiency red, 15mm (0.59")
Protection class front side	:	IP65
Protection class rear side	:	IP20
Screw terminals	:	Cross section max. 1.5 mm ² ,
Conformity and standards:		EMC 2004/108/EC: EN 61000-6-2 EN 61000-6-3 LV 2006/95/EC: EN 61010-1
Safety and Performance	:	MTBF: 45 years (Temp. = 60°C / 140°F) λ fit: 2539

With a redundant configuration (e.g. two monitors in parallel), this product is suitable for use with safety-relevant applications

- (a) Continuous serial communication may temporary increase response times
- (b) Diode or RC filtering is mandatory when switching inductive loads

10. Dimensions

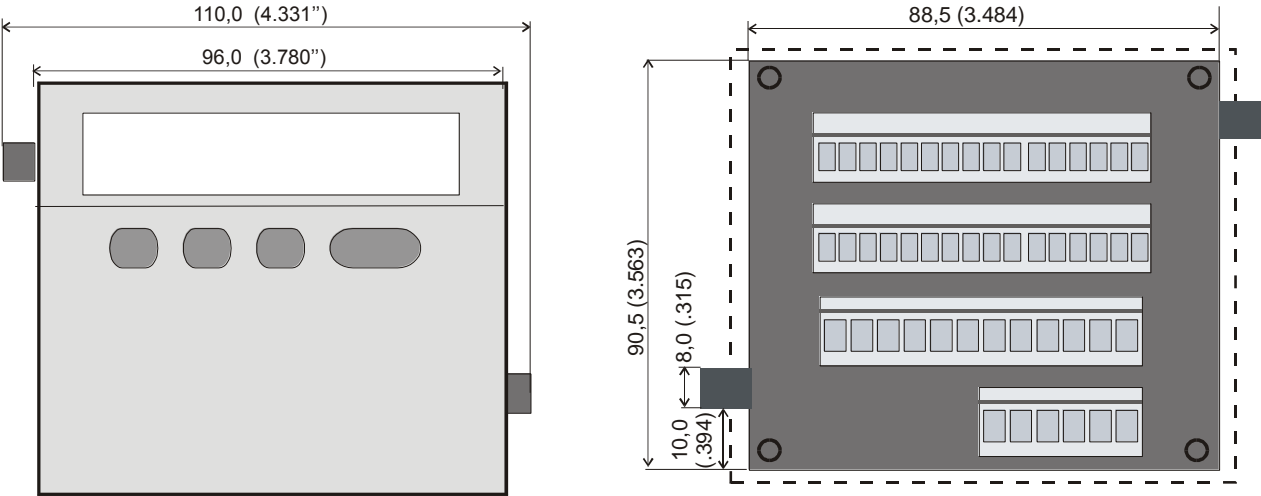

Panel cut out (b x h): 89 x 91 mm (3.504" wide x 3.583" high)