

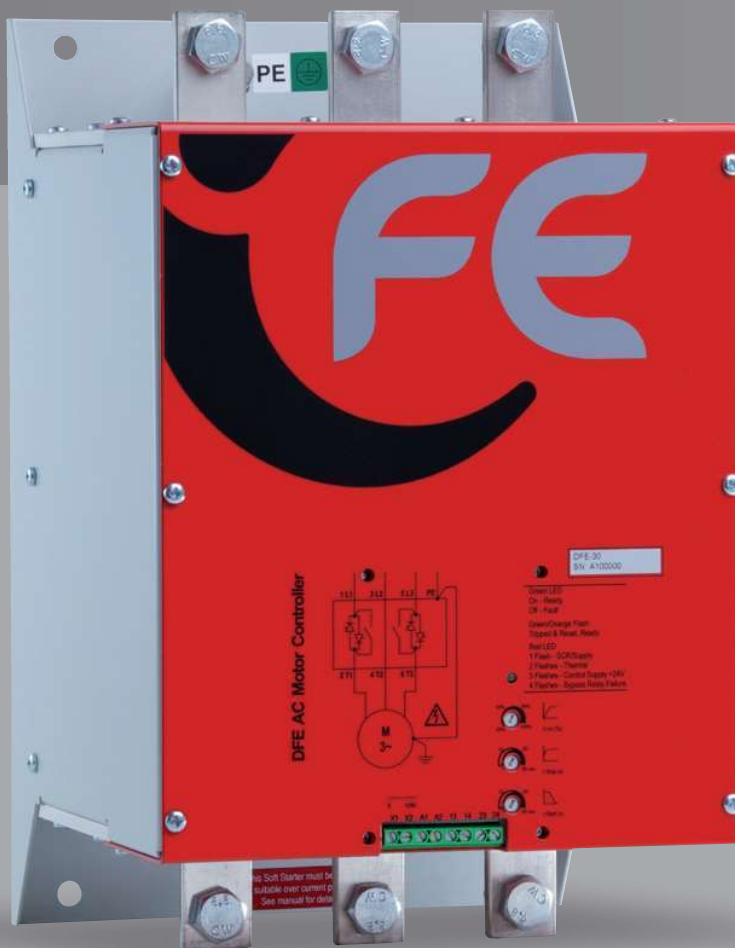

FAIRFORD
ELECTRONICS

DFE



**Fairford Electronics
low cost,
internally bypassed
non-optimising
Soft Starter**

DFE

The DFE is Fairford's internally bypassed, non-optimising Soft Starter which is perfect for panel builders and end users alike.



The DFE offers easy installation and is designed to be fitted with minimal disruption to production. The DFE is cost effective, low maintenance and has an excellent service lifetime.

To the user it offers competitive pricing, soft stopping and the removal of high transient currents. To panel builders it is an ideal substitute for a Star/Delta starter because it fits into a similar footprint, thus simplifying installation. It's now available from 22 Amps to 500 Amps.

Features and Benefits

Internally Bypassed
Internal bypassing of the Thyristors at the top of ramp allows for reduction in heat and cabinet size. Costs are reduced in ancillary equipment and these savings are passed on to the end user.

Substitution of Star/Delta Starters

- Lower maintenance costs
- Less stress on auxiliary equipment when starting
- Reduced down time
- Low cost of ownership

Simplified Installation
Rapid build and install time.

No need to change wiring configurations
All six wires of the Star/Delta configuration can be used to minimise installation and design costs.

Competitive with Star/Delta Starters

- Longer life
- Less maintenance
- Lower cost of ownership



DFE – Internally Bypassed Soft Starter 22 - 500 Amps

The DFE is Fairford's internally bypassed, non-optimising Soft Starter which is perfect for panel builders and end users alike.

To the user it offers competitive pricing, soft stopping and the removal of high transient currents. To panel builders it is an ideal substitute for a Star/Delta starter because it fits into a similar footprint, thus simplifying installation. It is now available from 22 Amps to 500 Amps.

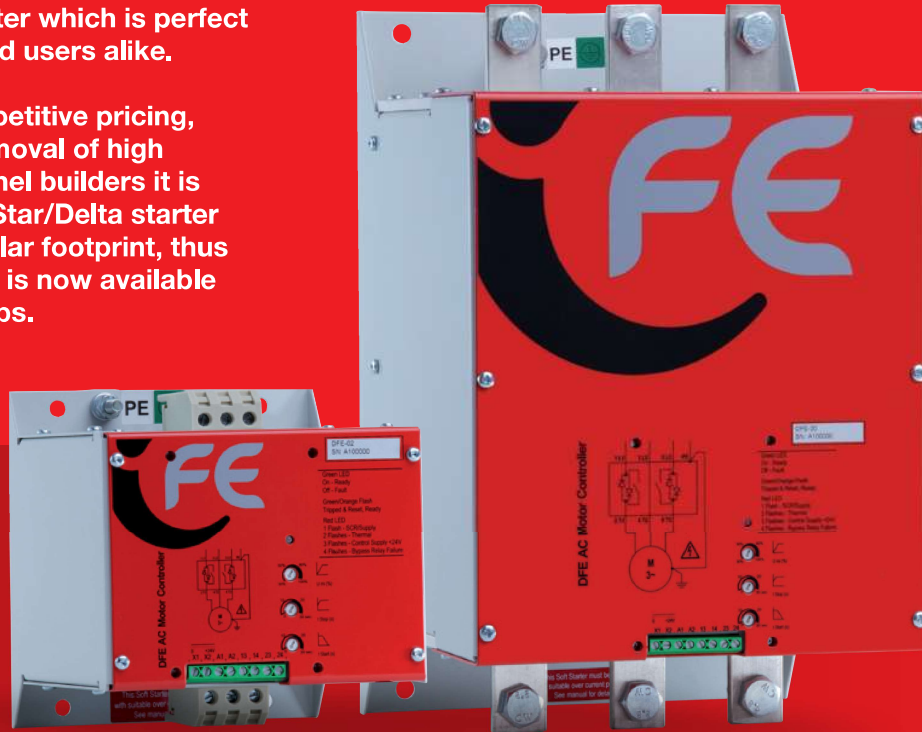

Case Study

Fairford is underlining the benefits of its Soft Starters for use in green energy systems with the application of a DFE Soft Starter to an innovative hydro power system. The system was installed by Derwent Hydroelectric Power at the Mill House, adjacent to 'Yvonne Arnault' theatre in Guildford, Surrey.

The installation of the hydroelectric turbine is part of a green energy initiative by Guildford Borough Council. Historically the Mill site was used to drive water pumps, but this fell into disuse in the 1960's. The installation of the Derwent water turbine continues the tradition of water power, but now the power generated - up to 45kW from a 1.8m head - is fed back into the local electricity supply network, generating energy cost savings for the local council.

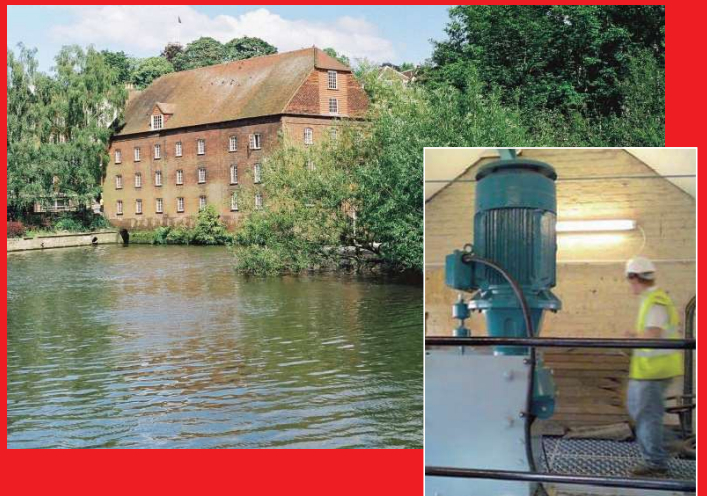

DFE - Technical data

Operational Voltage (Ue)	230-460VAC rms, 3-Phase (-15% +10%)
Rated Frequency	50 - 60Hz +/- 2Hz
Index Rating	Light Duty (DFE-02 - DFE-26) AC53b: 3-5: 355 Core Duty (DFE-02 to DFE-26) AC53b: 3.5-12: 708 Light Duty (DFE-30 - DFE-38) AC53b: 3-5: 355 Core Duty (DFE-30 - DFE-38) AC53b: 3.5-12: 1188
Start Time	0.5 to 30 Seconds
Stop Time	0 to 30 Seconds
Control Supply	24V DC Supplied externally to terminals X1-X2 DFE-34 to DFE-38 need a power supply capable of 3 amps for 1 second Power supply available, please contact Fairford for more details.
Soft Start/Stop Control	24V DC/110V AC galvanically isolated terminals A1-A2
Auxiliary Circuits (Relays)	Run - 13/14, Ready - 23/24. 230VAC 3A, Ac11
Indication	Multifunction LED on the front of the unit
Power Terminals	Input 1/L1, 3/L2 and 5/L3 Output 2/T1, 4/T2 and 6/T3 Up to 55kW IP20 rated wire clamping terminals 75kW to 280kW External Busbars
IP Rating	Up to 55kW IP20 75kW to 280kW IP00
Ambient Temperature	0°C to 40°C Above 40°C de-rate linearly by 2% of unit FLC per °C to a de-rate of 40% at 60°C
Transport and Storage	-25°C to +60°C
Altitude	1000m. Above 1000m de-rate linearly by 1% of unit FLC per 100m to a maximum altitude of 2000m
Humidity	Max. 85% non-condensing, not exceeding 50% at 40°C

DFE02 to DFE08

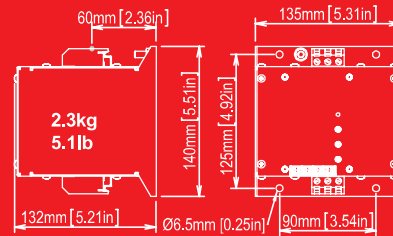

DFE12 to DFE16

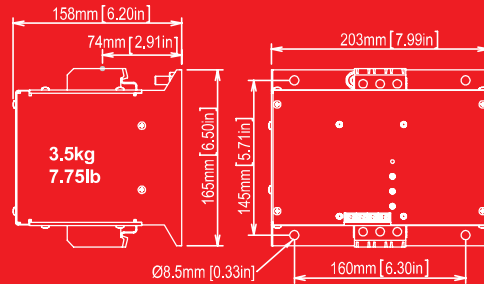

DFE22 to DFE26

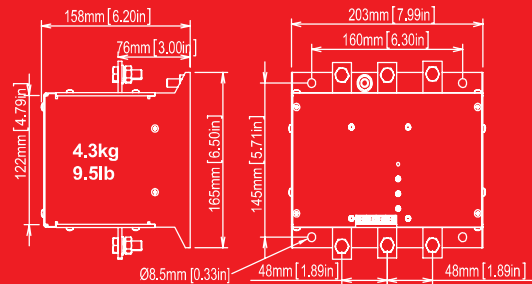

DFE30 to DFE38

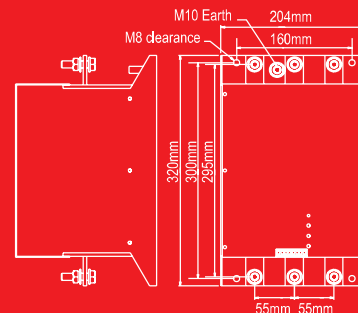

Please note: All dimensions in mm

For application specific sizing go to www.fairford.com and click product selector

Ie (A) 400V	kW 400V	HP 460V	Light Duty 3-5: 355	Core Duty 3.5-12: 708	Standard Duty 3-23: 697	Medium Duty 4-19: 701	Heavy Duty 4-29:691
22A	11kW	15HP	DFE 02	DFE 04	DFE 04	DFE 04	DFE 06
29A	15kW	20HP	DFE 04	DFE 06	DFE 06	DFE 06	DFE 08
35A	19kW	25HP	DFE 06	DFE 06	DFE 06	DFE 08	DFE 12
41A	22kW	30HP	DFE 06	DFE 08	DFE 08	DFE 12	DFE 16
55A	30kW	42HP	DFE 08	DFE 12	DFE 12	DFE 16	DFE 22
66A	37kW	54HP	DFE 12	DFE 14	DFE 14	DFE 22	DFE 22
80A	45kW	60HP	DFE 14	DFE 22	DFE 22	DFE 22	DFE 24
97A	55kW	75HP	DFE 16	DFE 22	DFE 22	DFE 24	DFE 26
132A	75kW	110HP	DFE 22	DFE 26	DFE 26	DFE 30	DFE 32
160A	90kW	130HP	DFE 24	DFE 30	DFE 30	DFE 32	DFE 34
195A	110kW	160HP	DFE 26	DFE 30	DFE 32	DFE 34	DFE 36
230A	132kW	190HP	DFE 30	DFE 32	DFE 34	DFE 36	DFE 38
280A	160kW	230HP	DFE 32	DFE 34	DFE 36	DFE 38	CALL
350A	200kW	290HP	DFE 34	DFE 38	DFE 38	CALL	CALL
382A	220kW	300HP	DFE 34	DFE 38	DFE 38	CALL	CALL
460A	250kW	350HP	DFE 36	CALL	CALL	CALL	CALL
500A	280kW	400HP	DFE 38	CALL	CALL	CALL	CALL

DFE – Accessories

PSU 5R Series



- 24VDC Power Supply for the DFE02 – DFE16 (Part Number – APSU005-R)
- Can control up to 4 DFE Soft Starters
- Input Voltage 90VAC – 264VAC
- Output Voltage 24VDC
- 18 Watt Output
- UL Listed

PSU 6R Series



- 24VDC Power Supply for the DFE22 – DFE38 (Part Number – APSU006-R)
- One Power Supply for each DFE Soft Starter
- Input Voltage 85VAC – 264VAC
- Output Voltage 24VDC
- 60 Watt Output
- UL Listed