

Incremental linear encoder
Robust type

SR84

- High rigidity provides resistance to shock and vibration
- Magnetic system allows use even in environments with condensation, oil, and other adverse conditions
- Same thermal expansion as iron



A/B/Reference point

Dimensions (cable left-lead out direction)

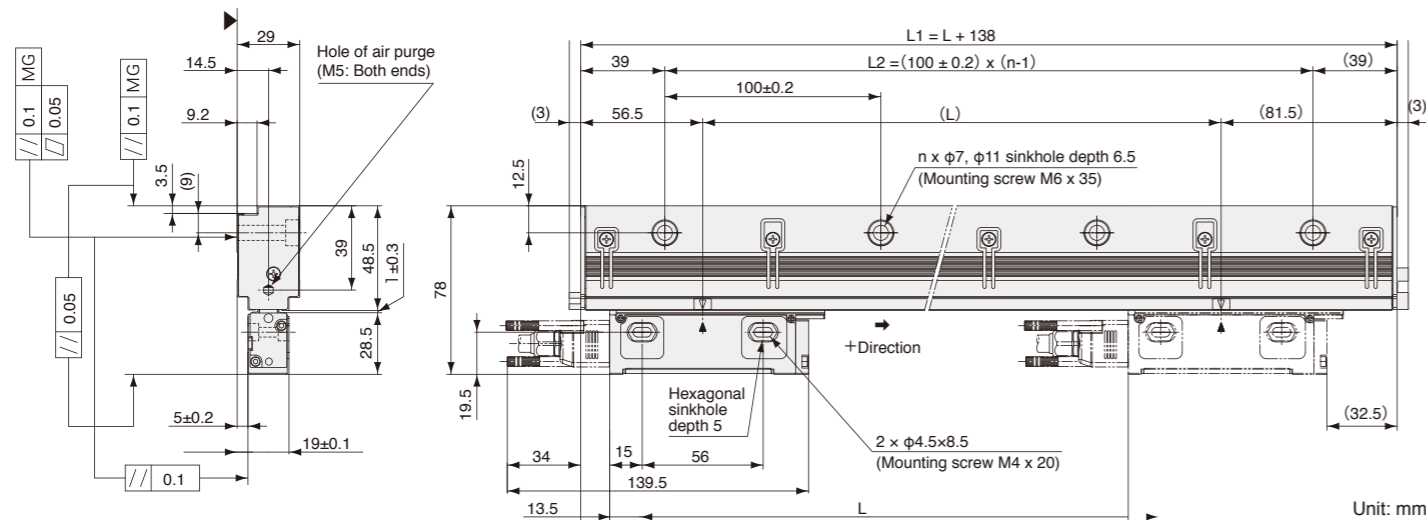

*When scale head moves in the direction of the arrow, positive polarity is addition and negative polarity is subtraction. *Cable leadout direction can be selected either right or left.

Effective length L	Total length L1	L2	n
140	278	200	3
240	378	300	4
340	478	400	5
440	578	500	6
540	678	600	7
640	778	700	8
740	878	800	9
840	978	900	10
940	1,078	1,000	11
1,040	1,178	1,100	12
1,140	1,278	1,200	13
1,240	1,378	1,300	14

Effective length L	Total length L1	L2	n
1,340	1,478	1,400	15
1,440	1,578	1,500	16
1,540	1,678	1,600	17
1,640	1,778	1,700	18
1,740	1,878	1,800	19
1,840	1,978	1,900	20
2,040	2,178	2,100	22
2,240	2,378	2,300	24
2,440	2,578	2,500	26
2,640	2,778	2,700	28
2,840	2,978	2,900	30
3,040	3,178	3,100	32

MG: Machine guide

- Notes**
- The surface indicated by the ▲ marks is the installation surface.
 - Screws indicated in the diagram are supplied as standard accessories.
 - Movement outside the effective length (L) will damage the scale head. It is recommended that the mechanical movable length (stroke) be set to 10 mm or more to the inside of both ends of the effective length (L).

Specifications

Model name	SR84
Effective length (L: mm)	140-3,040
Thermal expansion coefficient	12±1 × 10 ⁻⁶ /°C
Accuracy(at 20°C)	(3+3L/1,000) μmp-p or (5+5L/1,000) μmp-p L: Effective length (mm)
Reference point	None, Center point, Multi point, Signed-type, User-selected point (1 mm pitch)
Output signal	A/B/Reference point line driver signal, compliant with EIA-422
Resolution	Selectable from 0.05, 0.1, 0.5, and 1 μm (Set at factory shipping)
Maximum response speed	50m/ min (Resolution: 0.1 μm, Minimum phase difference: at 50 ns)
Functional safety	—
Legal compliance	FCC Part15 Subpart B Class A ICES-003 Class A Digital Device EN55011 Gp1 Class A, EN61000-6-2 Safety standards not applicable (60 V DC or less)
Operating temperature range	0 to +50°C
Storage temperature range	-20 to +55°C
Vibration resistance	250 m/s ² (50 Hz to 2,000Hz)
Impact resistance	450 m/s ² (11 ms)
Protective design grade	IP54 (Air purge not included), IP65 (Air purge included)
Power supply voltage range	DC+4.75 to +5.25 V
Maximum consumption current	1.0W or less (4.75V or 5.25V)
Consumption current	200mA (5V) (when the controller is connected)
Mass	Approx. 1.24kg+ 4kg/m or less
Standard compatible cable	CH33-***CP/CE
Maximum cable length	15 m

Details of model designation

Scale

SR84 - xxx★□◇# # #

[xxx]Effective length (L): cm units

[□]Resolution and direction (μm)

[# # #]Reference point position

[★]Cable lead-out direction

Type	Lead-out direction
R	Right
D	Down
L	Left

Type	Direction	Resolution	Type	Direction	Resolution
B		0.05	G		0.05
C	+	0.1	H	-	0.1
D		0.5	J		0.5
E		1.0	K		1

Reference point position	Indication method
Less than 1,000	Number (850 mm → 850)
1,000–1,099 mm	A + lower 2 digits (1,050 mm →A50)
1,100–1,199 mm	B + lower 2 digits
1,200–1,299 mm	C + lower 2 digits
1,300–1,399 mm	D + lower 2 digits
1,400–1,499 mm	E + lower 2 digits
1,500–1,599 mm	F + lower 2 digits
1,600–1,699 mm	G + lower 2 digits
1,700–1,799 mm	H + lower 2 digits
1,800–1,899 mm	J + lower 2 digits
1,900–1,999 mm	K + lower 2 digits
2,000–2,099 mm	L + lower 2 digits
2,100–2,199 mm	M + lower 2 digits
2,200–2,299 mm	N + lower 2 digits
2,300–2,399 mm	P + lower 2 digits
2,400–2,499 mm	Q + lower 2 digits
2,500–2,599 mm	R + lower 2 digits
2,600–2,699 mm	S + lower 2 digits
2,700–2,799 mm	T + lower 2 digits
2,800–2,899 mm	U + lower 2 digits
2,900–2,999 mm	V + lower 2 digits
3,000–3,040 mm	W + lower 2 digits
Center	X
Multi	Y
Signed-type	Z

[◇]Accuracy grade

Type	Accuracy grade
A	(5+5L/1,000) μmp-p
S	(3+3L/1,000) μmp-p

L: Effective length(mm)

[◇]Minimum phase difference

Type	Phase difference (ns)	Type	Phase difference (ns)	Type	Phase difference (ns)
A	50	F	300	L	1,250
B	100	G	400	M	2,500
C	150	H	500	N	3,000
D	200	J	650		
E	250	K	1,000		

Cable

CH33 - □□□▽※ #

[□□]Cable length
Written by flush right, indication in "m" units, up to 30 m, 1 m pitch (Example)

Type	Cable length	Type	Conduit
07	7m	C	With conduit (standard)
26	26m	N	Without conduit

[▽]Cable sheath (covering)

Type	Specification
P	PVC (Polyvinyl chloride)
E	PU (Polyurethane)

[※]Controller side connector

Type	Specification	Remarks
Without	Earth wire	
None	Open-end	Standard
A	D-sub 15P	
D	D-sub 9P	
L	10P made by Sumitomo 3M	Mitsubishi NC_J3 (A/B/Reference)
E	20P straight case made by Honda Tsushin Kogyo	FANUC (A/B/Reference)
G	6P made by molex®	YASKAWA Electric, Panasonic (INC serial, ABS)
H	R Horizontal drawing case made by HIROSE Electric	FANUC (A/B/Reference)

[#]Scale side connector

Type	Specification	Remarks
None	Original of Magnescale	Standard

*Relay type cannot be used for A/B/Reference type of SR74 and SR84

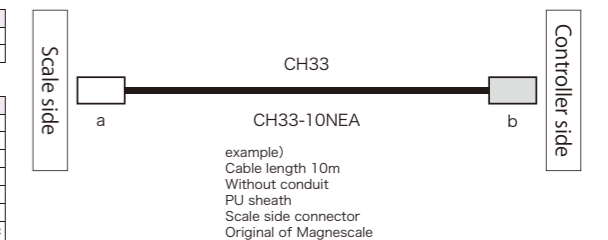

SR84
SR87A
SR74
SR74
SR84
RS97-004E
RS97-004N
RU97-004B
RU77-009B