



DC current sensors

Associated with DIRIS Digiware DC

Current sensors

new



tore_072_a.eps

Solid-core sensors 50 ... 600 A



tore_071_a.eps

Split-core sensors 50 ... 500 A



tore_068_a.eps

Solid-core sensors 850 ... 5000 A



tore_066_a.eps

Split-core sensors 800 ... 2000 A

The solution for

- > Data centre
- > Telecommunication
- > Renewable power
- > Transportation



Strong points

- > Plug & Play
- > Wide selection of ratings
- > Simplified installation

Compliance with standards

- > IEC 61010-1



- > UL



Function

The **DC current sensors** measure the DC load currents of an electrical installation and transmit information to the DIRIS Digiware Idc measurement modules via an RJ12 to Molex cable on the sensor side.

The range comprises solid-core and split-core sensors ranging from 50 to 5000 A in various sizes allowing them to be used in new or existing electrical installations.

Up to 3 different DC sensors can be connected to the same DIRIS Digiware Idc module.

Advantages

Plug & Play

- A quick RJ12 connection makes wiring easy and reliable.
- Fast configuration of the sensor's rating.

Flexible

- A complete range of solid-core and split-core sensors from 50 to 5000 A designed for new or existing electrical installations.

Installation

- Easy to install.
- Ideal for installations with limited space available.
- Only 4 different frame sizes cover a wide measurement range.
- Colour-coded cables for ease of identification, and to prevent wiring errors.

Dimensions (mm)

Solid-core sensors 50 ... 600 A (frame size 1)

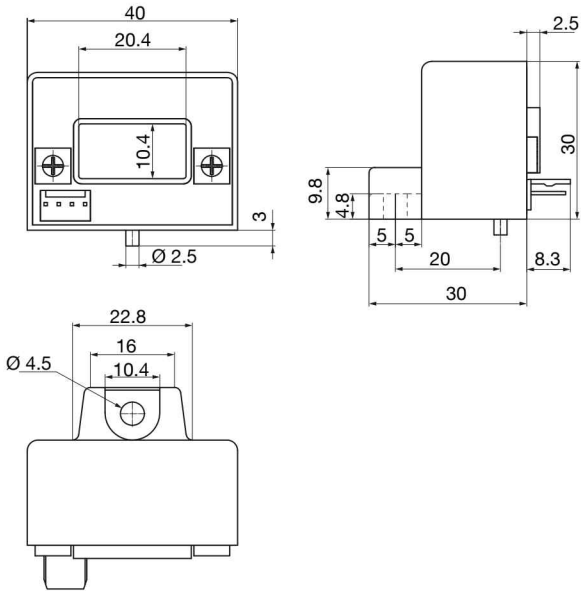

Solid-core sensors 850 ... 5000 A (frame size 2)

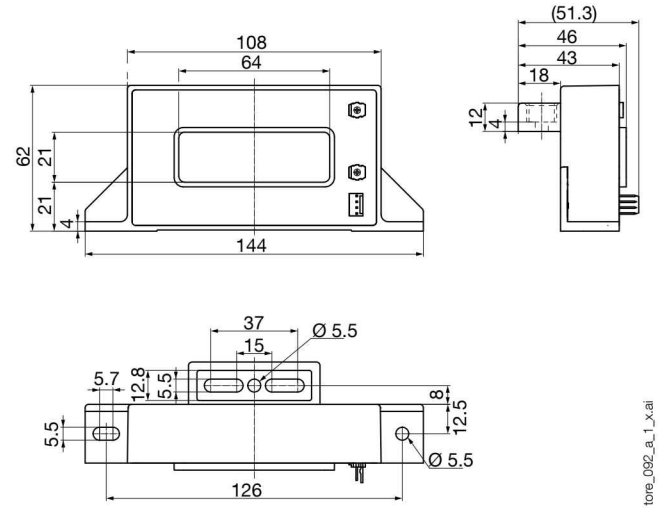

Split-core sensors 50 ... 500 A (frame size 1)

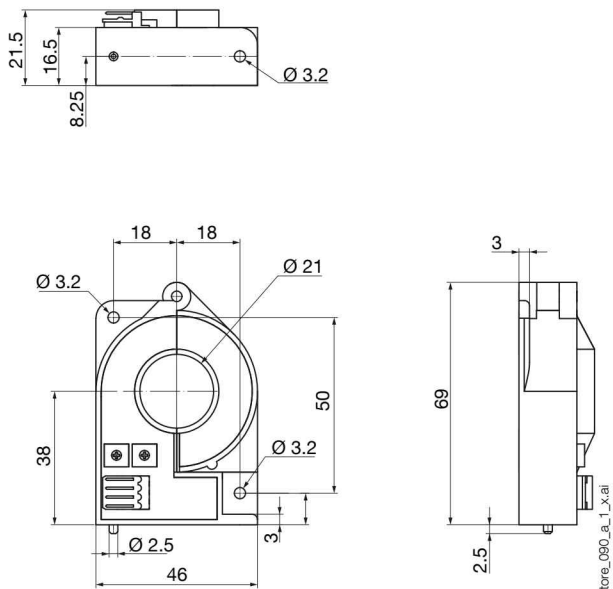

Split-core sensors 800 ... 2000 A (frame size 2)

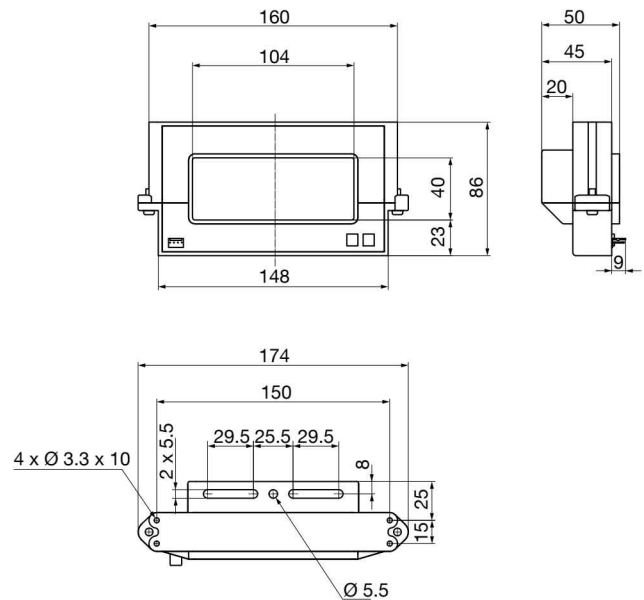

DC current sensors

Associated with DIRIS Digiware DC

Connections

DC current is measured by external sensors connected to the DIRIS Digiware I-3xdc modules via RJ12-Molex cables. Connection of the current sensors is quick and error-free. A wide range of current sensors is available from Socomec to suit all installations and applications including split-core current sensors for retrofit applications.

The DC current sensors have the following technical characteristics:

- Open-loop Hall effect sensors
- Solid-core or split-core.
- Power supply voltage: ± 15 V.
- Power supply current: ± 25 mA depending on the sensor.
- Output voltage: ± 4 V.
- 4-point male Molex terminal strip.
- Measurement range: 16 to 6000 A.
- Category III overvoltage.

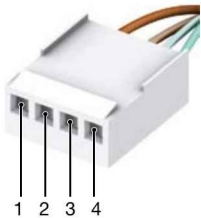

- PIN 1: + 15 V (+ Vc)
- PIN 2: - 15 V (- Vc)
- PIN 3: sensor input (M)
- PIN 4: 0 V sensor (0)

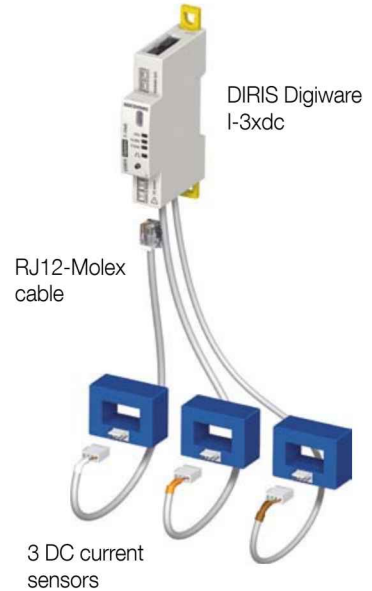

Technical characteristics

Type of current sensor	Open-loop Hall effect
Connection	Specific Socomec cable with RJ12-Molex connectors
Accuracy of current measurement	Solid-core sensors: 50 ... 600 A: < 1% Solid-core sensors: 850 ... 5000 A: < 1% Split-core sensors: 50 ... 500 A: < 2% Split-core sensors: 800 ... 2000 A: < 2%

Weight	Solid-core sensors 50 ... 600 A	60 g
	Solid-core sensors 850 ... 5000 A	450 g
	Split-core sensors 50 ... 500 A	80 g
	Split-core sensors 800 ... 2000 A	590 g
Operating temperature	Solid-core sensors 50 ... 600 A	-10 ... +80°C
	Solid-core sensors 850 ... 5000 A	-25 ... +85°C
	Split-core sensors 50 ... 500 A	-10 ... +70°C
	Split-core sensors 800 ... 2000 A	-10 ... +70°C
Storage temperature	Solid-core sensors 50 ... 600 A	-25 ... +80°C
	Solid-core sensors 850 ... 5000 A	-25 ... +85°C
	Split-core sensors 50 ... 500 A	-20 ... +85°C
	Split-core sensors 800 ... 2000 A	-25 ... +85°C

References

DC current sensors	Reference
Solid-core sensors (frame size 1)	
50 A	4829 0700
100 A	4829 0701
200 A	4829 0702
300 A	4829 0703
400 A	4829 0704
500 A	4829 0705
600 A	4829 0706
Solid-core sensors (frame size 2)	
850 A	4829 0707
1000 A	4829 0708
1500 A	4829 0709
2000 A	4829 0710
2500 A	4829 0711
5000 A	4829 0712
Split-core sensors (frame size 1)	
50 A	4829 0750
100 A	4829 0751
200 A	4829 0752
300 A	4829 0753
400 A	4829 0754
500 A	4829 0755
Split-core sensors (frame size 2)	
800 A	4829 0756
1000 A	4829 0757
1500 A	4829 0758
2000 A	4829 0759

RJ12-MOLEX cables		
Number of cables	Length of cables	Reference
3	0.3 m	4829 0782
3	0.5 m	4829 0783
3	1 m	4829 0784
3	2 m	4829 0785
1	5 m	4829 0786