

Motor Rating	3-Phase 200V
5.5kW (7.5HP)	LSLV055iV5L-4CNNN
7.5kW (10HP)	LSLV075iV5L-4CNNN
11kW (15HP)	LSLV110iV5L-4CNNN
15kW (20HP)	LSLV150iV5L-4CNNN
18.5kW (25HP)	LSLV185iV5L-4CNNN
22kW (30HP)	LSLV220iV5L-4CNNN

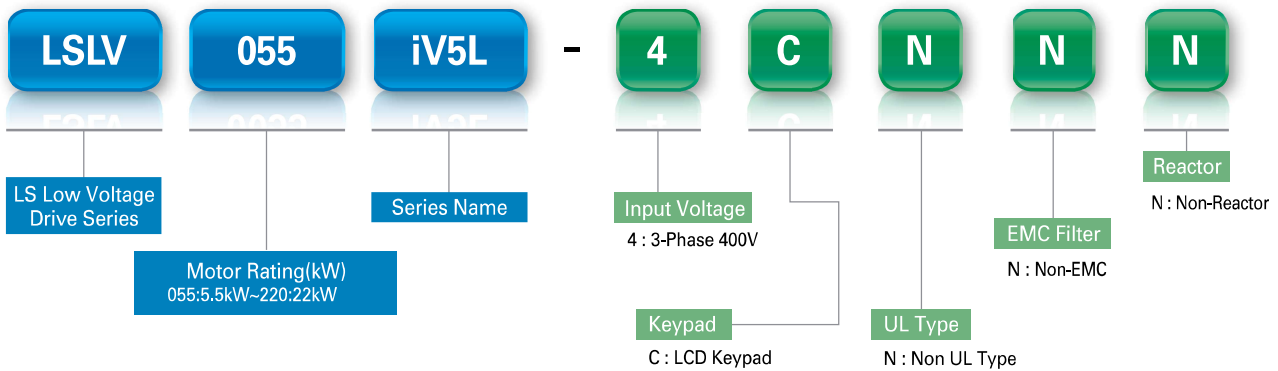
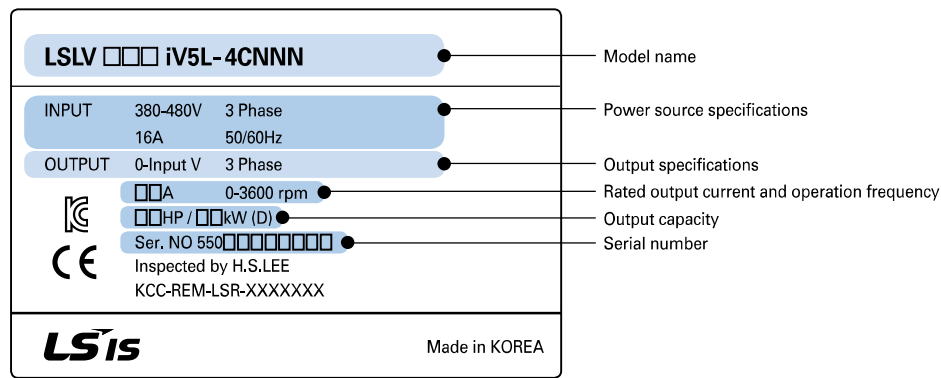

3-Phase 400V (5.5~22kW)

LSLV □□□ iV5L-4CNNN		055	075	110	150	185	220
Motor Rating	HP	7.5	10	15	20	25	30
	kW	5.5	7.5	11	15	18.5	22
Output Rating	Capacity [kVA]	9.1	12.2	18.3	22.9	29.0	34.3
	Rated Current [A]	12	16	24	30	39	45
	Speed	0~3600 rpm					
	Voltage [V]	0~380 V (480V)					
Input Rating	Voltage [V]	3-Phase 380-480 VAC (-10%~+10%)					
	Frequency [Hz]	50~60Hz (±5%)					
	Current [A]	17.5	24	28	35	46	53
Weight (kg(lbs))		7.7 (16.9)	7.7 (16.9)	13.7 (30.2)	13.7 (30.2)	20.3 (44.7)	20.3 (44.7)

- The standard motor capacity is based on a standard 4-pole motor.
- 400V Drives are designed for a 440V supply voltage.
- The maximum output voltage cannot exceed the input voltage.

Control

item	Description	
Circuit system	Voltage type Drive with IGBT	
Control method	Induction motor	Speed (sensored), V/F control, Slip compensation.
	Synchronous motor	Speed (sensored)
Speed control	Analog settings : $\pm 0.1\%$ ($25 \pm 10^\circ\text{C}$) of max speed (1800rpm)	
	Digital settings : $\pm 0.1\%$ ($0 \sim 40^\circ\text{C}$) of max speed (1800rpm)	
Speed setting resolution	Analog settings : $\pm 0.1\%$ of max speed Digital settings : 0.1rpm	
Speed control response speed	50Hz	
Overload capacity	Rated current : 150% 1 min.	
Acceleration / Deceleration	Time settings	0.00 ~ 600.0 sec
	Combination	4 acceleration/deceleration time choices
	Pattern	Linear, S-Curve

Operation

Braking	Braking method	Resistance discharge braking	
	Braking torque	150%	
	Braking resistor	External braking resistor (installation required)	
Input	Speed configuration	Digital settings via the keypad Analog input settings	Multistep configurations via terminal contact input Option settings
	Analog input	3 channels (AI1, AI2, AI3) - 10 \rightarrow 10V, 10 \rightarrow -10V, 0 \rightarrow 10V, 10 \rightarrow 0V, 0 \rightarrow 20mA, 20 \rightarrow 0 mA motor NTC (only available on AI3) 5 choices of multifunction analog input AI3 : Motor NTC can be used when using Higen motors	
	Terminal contact input	FX, RX, BX, RST, P1, P2, P3, P4, P5, P6, P7 26 function options using the multifunction input terminals (P1-P7).	
Output	Analog output	2 channels (AO1, AO2) - 10 \rightarrow 10V, 10 \rightarrow -10V, 0 \rightarrow 10V, 10 \rightarrow 0V output 30 multifunction analog output options	
	Terminal contact output	Multifunction terminal contact output : 2 channels (1A-1B, 2A-2B) Fault terminal contact output : 1 channels (30A-30C, 30B-30C)	
	Open collector output	1 channel (OC1/EG)	

Protective Function

Trip	Over Current, Ground Fault, Over Voltage, Low Voltage, Over Load, Inv OLT, InvOver Heat, InvThem OP, MotOver Heat, MotThem Err, E-Thermal, External-B, Arm Short, Arm Short-DB, Fuse Open, Encoder Err, BX, Over Speed, COM Error, HW-Diag, EEP Error, FAN Error, BatRUN Fault, Input PO, OUTput PO, SpdDev Err, Low Voltage 2, SAFETY A/B, A3 Safety, ADC Error, Flr/FHM Data, SINCOS Open, ENDAT ERROR
Alarm	Fan alarm, Drive overheat alarm, Motor overheat alarm, Overload alarm

Environment

Surrounding environment	Indoors, prevent contact with direct sunlight and corrosive gases (Pollution Degree 2 Environment).
Ambient temperature	- 10°C~40°C (no icing)
Ambient humidity	Relative humidity less than 90% RH (condensation must not form)
Cooling type	Forced fan cooling structure
Protection structure	IP00
Operation altitude/oscillation	No higher than 3,280 ft (1,000m). Less than 5.9m/sec ² (0.6G).