

## Pump Protection Relay (Three Phase)



### Description

Microprocessor based pump protection relay capable of protecting a submersible pump against all major power line faults. The unit calibrates itself under normal running conditions and stores these parameters in non-volatile memory. The unit also incorporate a reset delay for under current situations to enable the borehole to replenish itself. In an over current situation the unit will retry three times to prevent permanent tripping with temporary blockages.

### FEATURES

- Microprocessor based protection relay
- Over / Under Current Protection
- Over / Under Voltage Protection
- Phase Failure / Phase Reversal Protection
- Selectable Under Current Reset Delay
- Three retries for Over Current
- Automatic Self Diagnosis of Pump
- LED indication for all faults

### Input Specifications

Current Input	Pin 6 & 10
Measuring Ranges	1 - 5A
Over Current Limit	12% (17% extended)
Recovery Time	15 sec (3 attempts then permanent OFF)
Under Current Limit	8% (12% extended)
Recovery Time	1, 2, 4, 8hrs
Maximum Overload	10A (30sec)
Current	
Voltage Input	Pin 1, 2, 11
Measuring Range	320 - 460VAC
Over / Under Voltage	± 15% (20% extended)
Limit	
Hysteresis	5%

### Supply Specifications

Power Supply AC Type	110, 230, 400V (Galvanic)
	525V ± 10%
	50 / 60 Hz ± 5Hz
Isolation	4kV
Consumption	± 3VA ± 6VA 525 V

### Output Specifications

Output Specifications	SPDT
Rated Isolation	6000 VAC (contact / electric)
Voltage	1000 VAC (contact / contact)
Nominal Rate in AC1	1500 VA ( Ag-Ni )
Rated Current	10A
Rated Voltage	250V
Mechanical Life	10x10 <sup>6</sup> cycles
Electrical Life	110x10 <sup>3</sup> cycles (at max load)
Operation Frequency	≤ 1800 cycles/h

### General Specifications

Power ON Delay	≤ 300 ms
Power OFF Delay	≤ 200 ms
Indication for	
Relay ON	LED green
Power ON	LED red
Over Voltage	_ _ _
Under Voltage	_ . .
Over Current	. _ _
Under Current	. . .
Security switch open	. _ .
Environment	
Degree Of Protection	IP 20
Operating Temperature	-10 to + 50°C
Storage Temperature	-50 to + 85°C
Weight	200g

## Pump Protection Relay (Three Phase)

### Mode of Operations

#### Voltage Monitoring

The unit monitors voltage continuously and will trip the pump if the voltage rises or drops below the set parameters. After the fault has corrected itself the unit will automatically restart the pump and resume normal operation.

#### Example

- Unit calibrated at 230 VAC without extending the parameters will trip at 258V and 202V.
- The unit is calibrated at 225V with extended parameters. The unit will trip at 270V and 180V.

#### Security Switch Trip

The security switch should control all manual pump operations. Any monitoring equipment i.e. level controllers, pressure switches or time switches would be connected in series between contact 7 & 8. The pumps ON/OFF control switch should also be connected in series to above contacts.

#### Current Monitoring

The unit starts monitoring current after the 6 sec start-up delay. If the current drops below the set parameter the unit will trip the pump for the DIP switch selectable recovery time. If the current rises above the set parameter, the unit will trip for  $\pm 10$  sec, after which the pump will restart. If an over current condition is detected three consecutive times the unit will trip permanently until the power is removed and reapplied.

#### Example

- Unit calibrated at 25A with a 30/5 CT with extended parameters will trip at 29A and 22A.
- A unit calibrated at 4.5A connected directly to the motor (no CT) without extending the parameters will trip at 5.27A and 3.96A.

#### Star / Delta Connection

If the pump connected to the Lp3 is a star/delta, contacts 8 & 9 must be closed until the delta contact comes in, after which the unit will start up as normal. This prevents any nuisance tripping in the transition between star and delta.

### Wiring Diagram

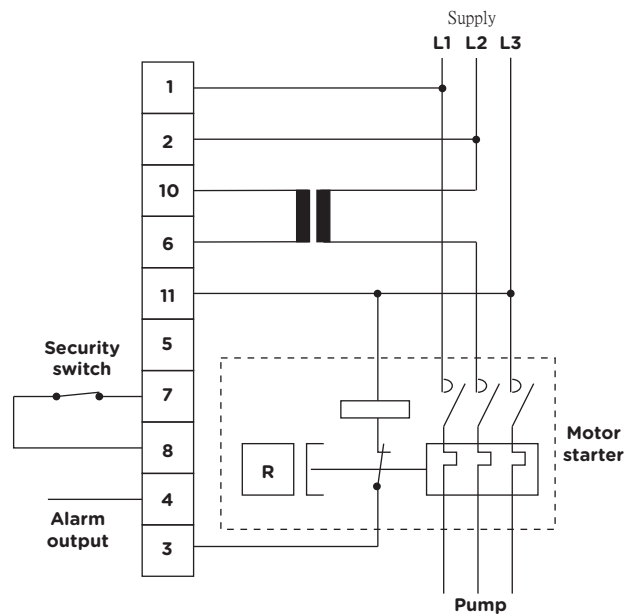
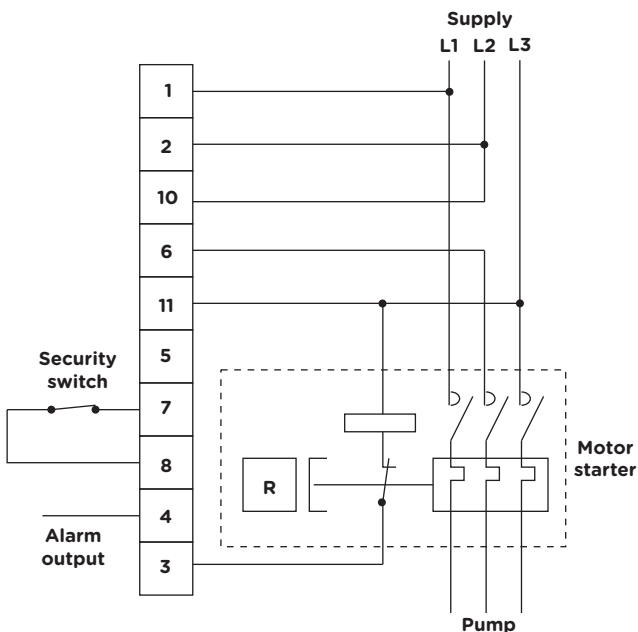

## Pump Protection Relay (Three Phase)

### Operations Diagram

