



Product designation
 Product type designation

Legend holder
 8LM2TAU100

Mechanical features

Weight

g 1

Dimensions

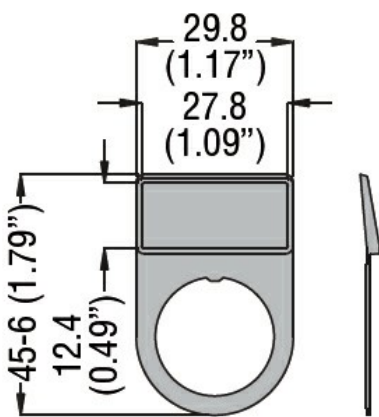

Certifications and compliance

Compliance

/

Certificates

/

ETIM classification

ETIM 8.0

EC000624 - Text
 plate for
 command
 devices