



OCS NX Series

Want More Information?
To download the NX User Manual (MAN0781), refer to *Technical Support* in this document.

1 INTRODUCTION

The Horner NX Series OCS is a cost effective family of high performance all-in-one controllers. The NX features an advanced control engine, operator interface, local and remote I/O capabilities (including built-in HSC and PWM for specific models), and a variety of communications options. The NX is extremely versatile, adept at a variety of factory automation functions. The NX can be used to perform advanced machine control, factory machine monitoring, RTU-type functions, and much more.

2 SPECIFICATIONS

Table 1 – NX Series OCS Specifications						
	NX220	NX221	NX222	NX250	NX251	NX252
Input Voltage	10 to 32 VDC					
Screen Type	128x64 LCD Backlit, monochrome			240x128 LCD Backlit, monochrome		
LCD Backlighting	Green, Red, or Off (selectable)			Green or Off (selectable)		
Keypad / LEDs	20 keys (10 fn keys) plus 10 LEDs			24 keys (10 fn keys) plus 10 LEDs		
Keypad Type	Tactile Dome (1 million operations) plus defeatable Audible feedback					
Application Memory: Graphics	1 M byte					
Control Memory	256K Ladder Memory plus 32KB Register Space					
Control Scan Rate	0.1mS / K Ladder Logic (typical)*					
I/O Interfaces	Plastic SmartStack I/O – 4 modules maximum Fiber Optic Expansion (FOX) I/O – 5 bases maximum CsCAN Network Port – 252 SmartStix I/O maximum					
Built-in High Speed Counter / PWM	No	No	Yes - >1MHz max TTL or 24vdc level	No	No	Yes - >1MHz max TTL or 24vdc level
Built-in PWM Outputs	No	No	Yes 24vdc level	No	No	Yes 24vdc level
Portable Memory	Compact FLASH (CF) slot (up to 2GB)					
Battery	Replaceable 3V Lithium battery – 4.5 years (off) lifetime					
Ethernet Ports	No	10/100MHz		No	10/100MHz	
Serial Ports	1 shared port (RS-232 DE-9S** & RS-232/485 RJ45) – software selectable 1 dedicated port (RS-232/485/422 on a 10-pin terminal strip)					
Power Requirements (without I/O)	Steady State Current: 400mA @24VDC Inrush Current: 28A for 1ms @24VDC					
Temperature & Humidity	32 - 122°F (0 - 50°C), 5 to 95% Non-condensing					
UL	Please refer to Compliance Table located at http://www.heapg.com/Support/compliance.htm					
CE						
Environment	Designed for installation in a NEMA 12 environment. Optional mounting kit HE-ACC006 allows mounting in a NEMA 4/4X or IP65 environment.					
* Total ladder scan is impacted by several factors – logic, I/O, screen and communications update.						
** Denotes 9-pin, 2-row, socket. The term DB9 is widely (but erroneously) used to specify a 9-pin RS-232 connector. The correct specifier is either a DE-9S (socket) or a DE-9P (plug).						

3 INSTALLATION PROCEDURE

3.1 Overview of Required Steps

1. Per the specifications of **Figure 1** and **Figure 2** – carefully prepare the panel cutout. Make sure the corners of the cutout are square and free from burrs.
2. Place the OCS in the panel cutout. Secure the unit as shown in **Figure 3** using the four (4) supplied mounting clamps. **Figure 4** shows the possible clamping locations (10 possible), and the locations recommended for most applications. **For NEMA 4/4X washdown applications, the optional accessory kit HE-ACC006 is required.** This kit includes six additional mounting clips so that all mounting locations can be secured to provide an optimum seal against leaking.
3. As a final step prior to commissioning, carefully remove the protective, plastic sheet from the front of the unit. The protective, transparent sheet is used to protect the display window.

CAUTION: Remove the plastic sheet slowly, from corner to corner, so as not to stretch the NX keypad/display overlay.

3.2 Dimensions

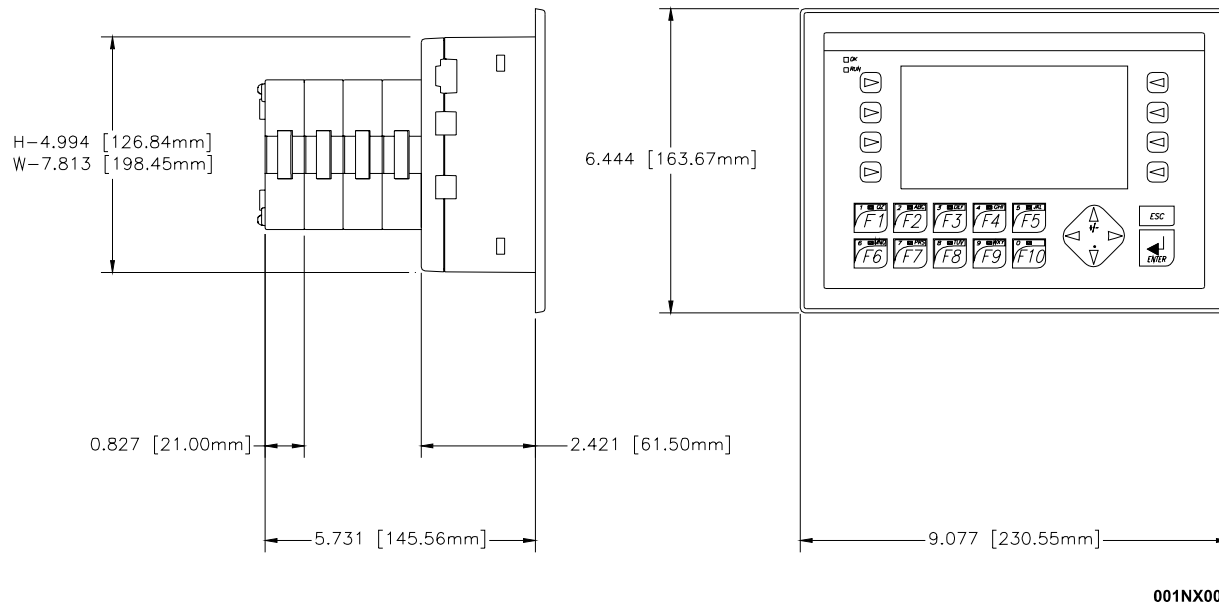

001NX003

Figure 1 – Dimensions for the NX (NX25x is shown but dimensions apply to all NX Models)
(Left figure shows side-view of NX with 4 SmartStack Modules attached.)
(Right figure shows front view.)

3.3 Panel Cut-Out

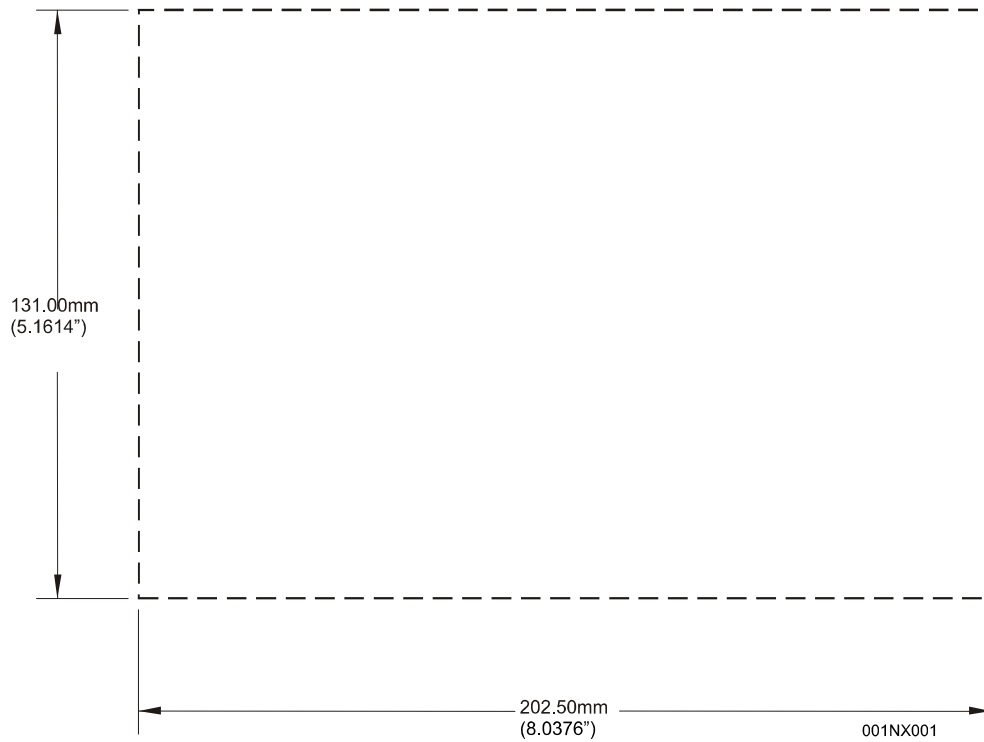

Figure 2 – Panel Cut-Out for the NX

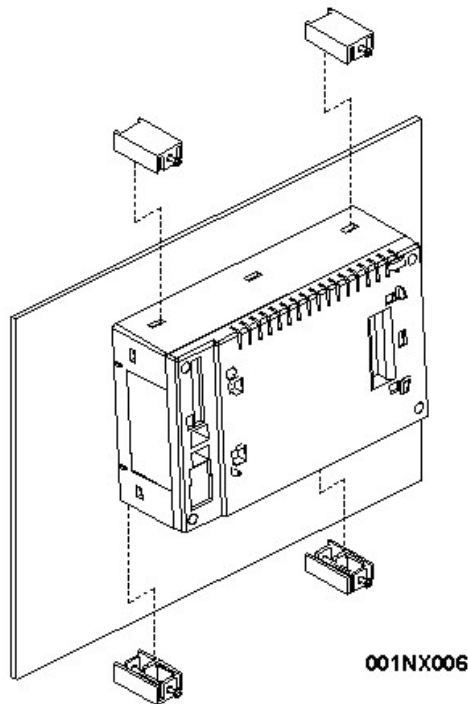

Figure 3 – Four Standard Mounting Clips

Figure 4 shows locations for **four standard** mounting clips and also **six additional** clips contained in optional accessory kit **HE-ACC006**, which is required for NEMA 4/4X or IP65 washdown applications.

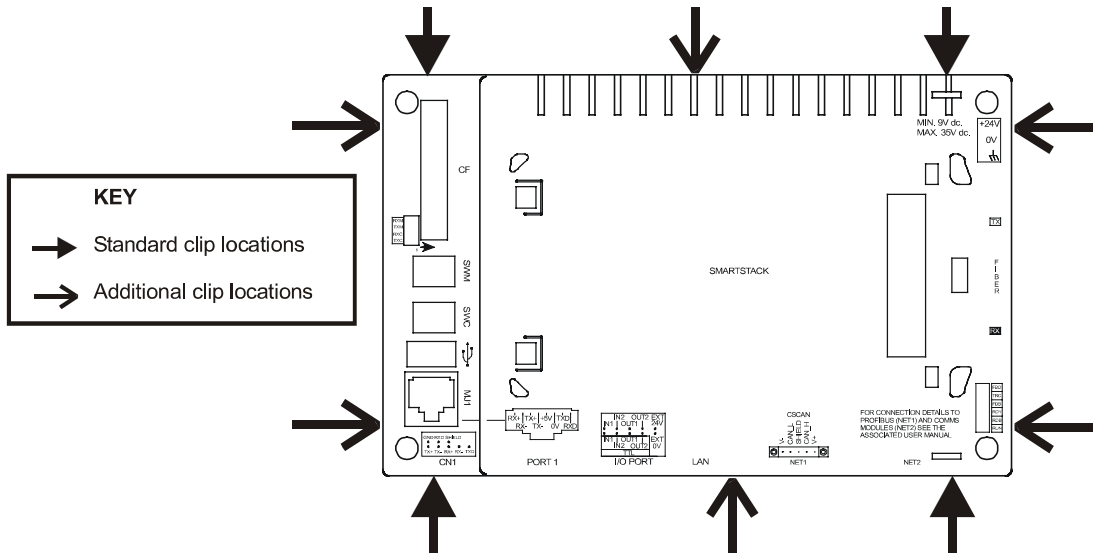

Figure 4 – Locations for 10 Mounting Clips for Optimum Seal Against Leaking (Extra Clips required for NEMA 4/4X or IP65 washdown applications.)

3.4 Ports, Connectors and Wiring

Figure 5 shows the locations of the most common connectors used during installation.

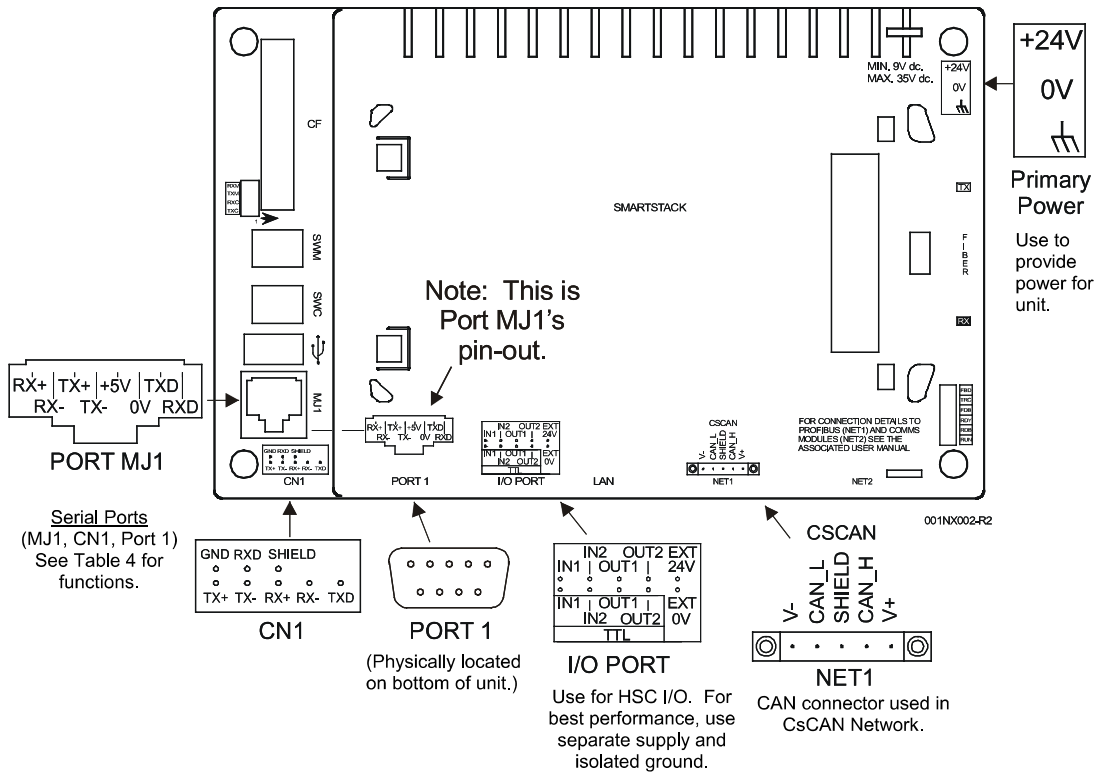



Figure 5 – Overview of NX Connectors

3.4.1 Primary Power Port

Table 2 – Primary Power Port Pins		
Pin	Signal	Description
1		Frame Ground
2	0V	Input power supply ground
3	+24V	Input power supply ground voltage

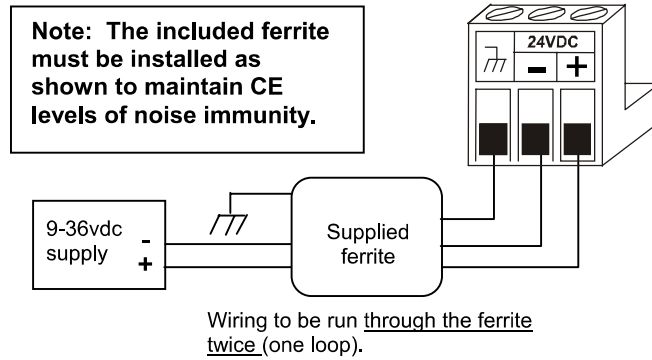

Figure 6 - Power Connector (Primary Power Port)

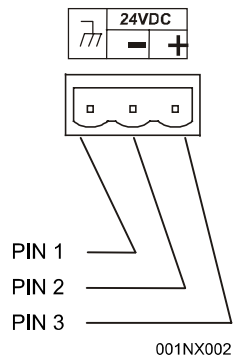

Figure 7 - As viewed looking at the NX

3.4.2 CAN Network Port and Wiring

See the latest edition of Horner's **CAN Networks Manual** (MAN0799) by referring to the website location listed *Section 6: Technical Support* in this document.

Note: To optimize CAN network reliability in electrically noisy environments, the V- CAN Ground needs to be isolated from the primary input power supply ground.

3.4.3 RS-232/ RS-485 Programming Ports and Wiring

The NX features two active serial ports, accessible through three connectors. Port 1 and MJ1 share internal OCS circuitry. These two ports can NOT be used simultaneously. Port CN1 has independent circuitry, and can be used simultaneously to either Port 1 or MJ1.

Note: In certain applications, both Port 1 and MJ1 can be used, but the OCS application program must select the port which is active at any given time. **Table 4** shows the three port connectors and the functions supported by each.

Table 4 – Serial Ports and Functions (Port 1, MJ1 and CN1)										
Port	Connector	RS-232	RS-422	RS-485	Cscape Programming	Full Modem Support	ASCII	RTU Slave	RTU Master	3rd Party Protocols
Port 1	DE-9S*	x			x	x	x	x	x	x
MJ1	RJ45	x	x	x	x	**	x	x	x	x
CN1	10-pin Terminal	x	x	x		**	x	x	x	x

* Denotes 9-pin, 2-row, socket. The term DB9 is widely (but erroneously) used to specify a 9-pin RS-232 connector. The correct specifier is either a DE-9S (socket) or a DE-9P (plug).
 ** Does not support handshaking.

a. PORT 1 – 9-pin D-subminiature Jack

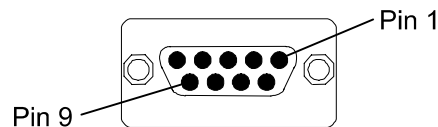

Note: The term DB9 is widely (but erroneously) used to specify a 9-pin RS-232 connector. The correct specifier is either a DE-9S (socket) or a DE-9P (plug).

Figure 8– PORT 1 RS-2323 Port DE-9S Connector.

Table 5– PORT 1 RS-232 Port Pins			
Pin	Signal	Description	Dir
1	DCD	Always high	Out
2	RXD	Received Data	Out
3	TXD	Transmitted Data	In
4	DTR	Data Terminal Ready	In
5	GND	Ground	-
6	DSR	Data Set Ready	Out
7	RTS	Request to Send	In
8	CTS	Clear to Send	Out
9	RI	Ring Indicate	Out

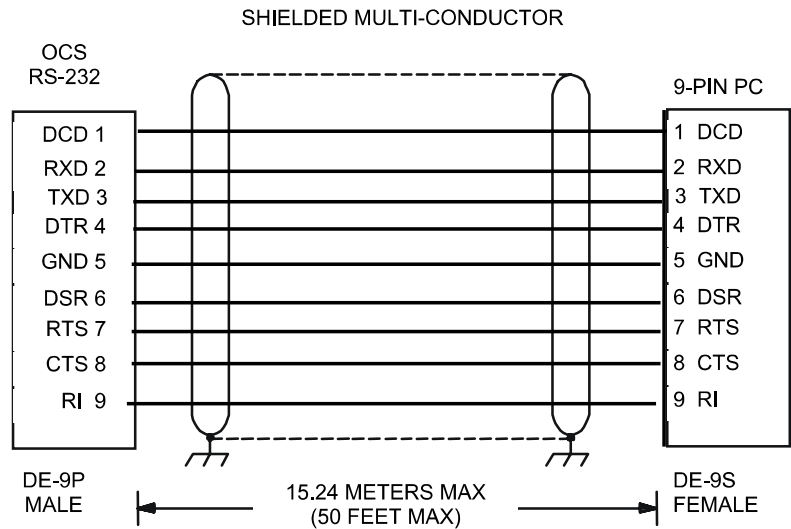

Note: For baud rates greater than 9600 baud, a shorter cable may be required.

Figure 9 –Programming Cable (9-pin)

b. MJ1 Modular Jack

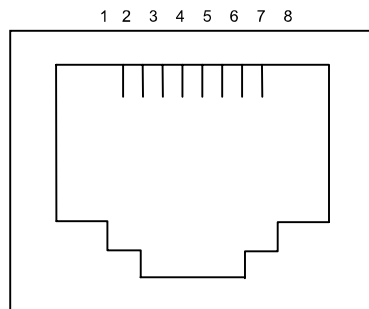

Note: See Table 4 for a list of serial port functions.

Figure 10 – Serial Port MJ1 RJ-45 Jack

Table 6 – MJ1 Serial Pins		
Pin	Signal	Direction
1	RX+	IN
2	RX-	IN
3	TX+	OUT
4	TX-	OUT
5	+5V	OUT
6	0V	-
7	RXD	IN
8	TXD	OUT

c. CN1 10-pin Terminal Header

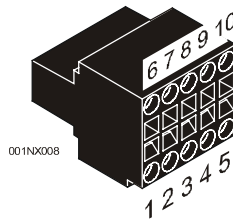

Note: See Table 4 for a list of serial port functions.

Figure 11 – CN1 Serial Terminal Connector

Table 7 – CN1 Pins (Black Connector)		
Pin	Signal	Direction
1	TX+	OUT
2	TX-	OUT
3	RX+	IN
4	RX-	IN
5	TXD	OUT
6	GND	-
7	RXD	IN
8	SHIELD	-
9	+5V	OUT
10	N/C	-

3.5 I/O Port for Built-in High Speed Communications (HSC)

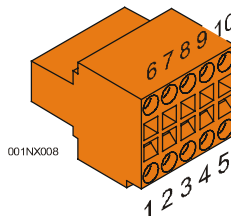

Want More Information on NX HSC and PWM?

Download the *NX User Manual* (MAN0781) and refer to the Built-in HSC chapter, which covers configuration, wiring, and other pertinent topics. See *Technical Support* for our website address.

Figure 12 – I/O Port (HSC) Terminal Connector

Table 8 – I/O Port Pins (HSC) (Orange Connector)		
Pin	Signal	Description
1	TTL In1	HSC 1 / 5 V Input 1 (See Note*)
2	TTL In2	HSC 2 / 5 V Input 2 (See Note*)
3	TTL In3	HSC 3 / 5 V Input 3 (See Note*)
4	In3	HSC 3 / 24 V Input 3 (See Note*)
5	0 V	Ground (For best performance, use separate supply and isolated ground.)
6	In1	HSC 1 / 24 V Input 1 (See Note*)
7	In2	HSC 2 / 24 V Input 2 (See Note*)
8	Out1	Output 1 / PWM 1
9	Out2	Output 2 / PWM 2
10	+24 V	Power for Outputs
<p>Note* - Depending on the output of the application, use 5 V (e.g., TTL In1) <u>or</u> 24 V (e.g., In1) <i>per channel</i>.</p>		

3.6 NX DIP Switches

Table 9 – NX DIP Switches			
Port	Connector	Description	DIP Switch Positions
MJ1	RS-485	RX BIAS	SWM-1 ON and SWM-3 ON
MJ1		TERMINATION	SWM-2 ON
MJ1		HALF-DUPLEX	SWM-4 ON and SWC-4 ON
CN1		RX BIAS	SWC-1 ON and SWC-3 ON
CN1		TERMINATION	SWC-2 ON

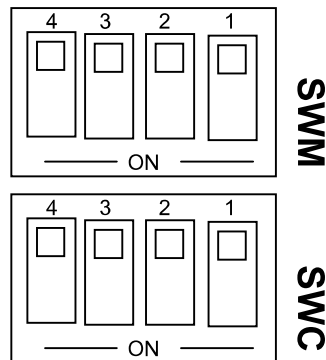

Figure 13 – DIP Switches (Switches Shown here in OFF Position)

4 SAFETY

When found on the product, the following symbols specify:



Warning: Consult user documentation.



Warning: Electrical Shock Hazard.

WARNING: To avoid the risk of electric shock or burns, always connect the safety (or earth) ground before making any other connections.

WARNING: To reduce the risk of fire, electrical shock, or physical injury it is strongly recommended to fuse the voltage measurement inputs. Be sure to locate fuses as close to the source as possible.

WARNING: Replace fuse with the same type and rating to provide protection against risk of fire and shock hazards.

WARNING: In the event of repeated failure, do not replace the fuse again as a repeated failure indicates a defective condition that will not clear by replacing the fuse.

WARNING: Only qualified electrical personnel familiar with the construction and operation of this equipment and the hazards involved should install, adjust, operate, or service this equipment. Read and understand this manual and other applicable manuals in their entirety before proceeding. Failure to observe this precaution could result in severe bodily injury or loss of life.

For detailed installation and a handy checklist that covers panel box layout requirements and minimum clearances, refer to the hardware manual of the controller you are using. (See the **Additional References** section in this document.)

- All applicable codes and standards need to be followed in the installation of this product.
- For I/O wiring (discrete), use the following wire type or equivalent: Belden 9918, 18 AWG or larger.

Adhere to the following safety precautions whenever any type of connection is made to the module.

- Connect the green safety (earth) ground first before making any other connections.
- When connecting to electric circuits or pulse-initiating equipment, open their related breakers. Do not make connections to live power lines.
- Make connections to the module first; then connect to the circuit to be monitored.
- Route power wires in a safe manner in accordance with good practice and local codes.
- Wear proper personal protective equipment including safety glasses and insulated gloves when making connections to power circuits.
- Ensure hands, shoes, and floor are dry before making any connection to a power line.
- Make sure the unit is turned OFF before making connection to terminals. Make sure all circuits are de-energized before making connections.
- Before each use, inspect all cables for breaks or cracks in the insulation. Replace immediately if defective.

5 ADDITIONAL REFERENCES

The following information serves as a *general* listing of Horner controller products and other references of interest and their corresponding manuals numbers. Visit our website listed in the **Technical Support** section to obtain user documentation and updates.

Note: This list is <u>not</u> intended for users to determine which products are appropriate for their application; controller products differ in the features that they support. If assistance is required, see the Technical Support section in this document.	
Controller	Manual Number
XLE Series (e.g., HE-XExxx)	MAN0805
QX Series (e.g., HE-QXxxx)	MAN0798
NX Series (e.g., HE-NXxxx)	MAN0781
LX Series (e.g., LX-xxx; also covers RCS116)	MAN0755
Color Touch OCS (e.g., OCSxxx)	MAN0465
OCS (Operator Control Station) (e.g., OCS1xx / 2xx; Graphic OCS250)	MAN0227
Remote Control Station (e.g., RCS2x0)	
MiniOCS (e.g., HE500OCSxxx, HE500RCSxxx)	MAN0305
Other Useful References	
CAN Networks	MAN0799
Cscape Programming and Reference	MAN0313
Wiring Accessories and Spare Parts Manual	MAN0347

6 TECHNICAL SUPPORT

For assistance and manual updates, contact Technical Support at the following locations:

North America:
(317) 916-4274
www.heapg.com
email: techspt@heapg.com

Europe:
(+) 353-21-4321-266
www.horner-apg.com
email: techsupport@hornerirl.ie