

SMARTSTACK DATASHEET

HE800ADC140 / HE-ADC140 (Plastic Cases) 16-Bit Resolution

NOTE: This datasheet also covers products with IC300.

1 TECHNICAL SPECIFICATIONS

SPECIFICATIONS			
ADC140			
Number of Channels	4	Common Mode Range	+/- 12VDC
Analog Inputs Input Points Required	4	Conversion Time (PLC Update Rate)	313ms for all 4 channels
		PLC Update Rate	Set by PLC Scan Rate
Resolution	16-Bit	Terminal Type	Spring Clamp, Removable
		Additional error for temperatures other than 25°C	0.01% / °C
Maximum Error @ 25°C	0.05% Full Scale	Operating Temperature	0° to 60°C
Input Impedance	5 Ω	Relative Humidity	5 to 95% Non-condensing
Required Power (Steady State)	0.62W (26mA @ 24VDC)	Weight	9.5 oz. (270g)
Required Power (Inrush)	Negligible	Certifications (CE)	
Maximum Overcurrent	100mA	USA: https://hornerautomation.com/certifications/	
External Power Supply	None	Europe: www.hornerautomation.eu	

2 WIRING I/O

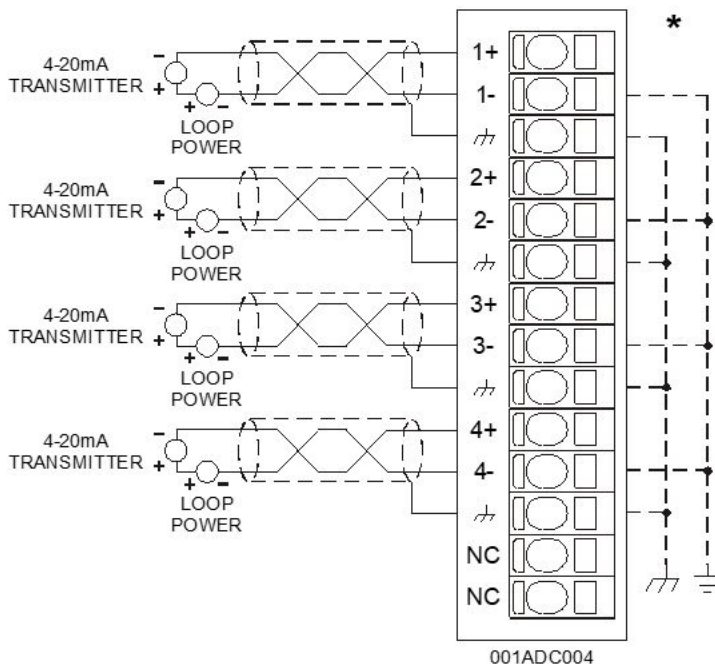

page 1 of 4

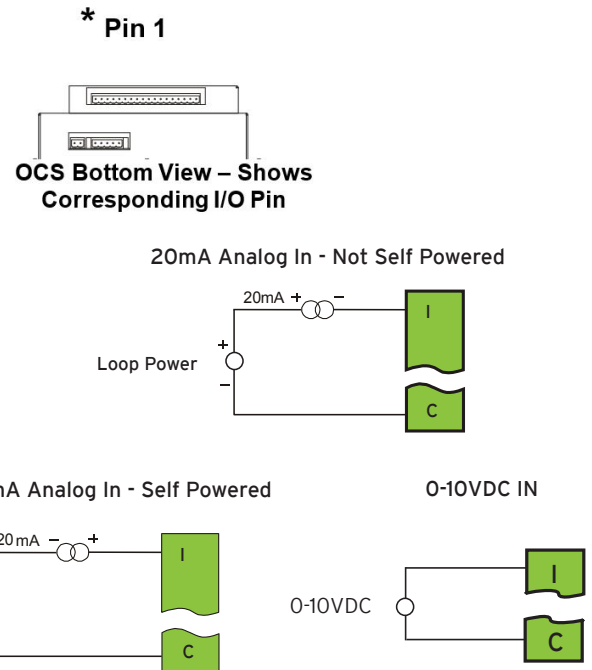

wiring I/O continued on next page...

wiring I/O continued...

For installation, use twisted pairs (shielded preferred).

The differential inputs must be maintained within the specified common mode range for proper operation. One way to ensure this is to connect one side of each input to the OCS power supply common potential.

Exceeding the common mode range on an input channel results in erroneous readings on that channel. Failure to connect one side of a differential input results in an effective zero reading. A reversed connection of a differential input pair results in sign reversed digital data into the PLC for that channel.

Name	Pin	ADC140
1+	1*	20mA 1+
1-	2	20mA 1-
	3	Shield
2+	4	20mA 2+
2-	5	20mA 2-
	6	Shield
3+	7	20mA 3+
3-	8	20mA 3-
	9	Shield
4+	10	20mA 4+
4-	11	20mA 4-
	12	Shield
	13	No Connection
	14	No Connection

* See Wiring drawing

3 CONFIGURATION

NOTE: The status of the I/O can be monitored in Cscape.

Preliminary configuration procedures that apply to SmartStack Modules are contained in the user manual of the controller, which can be found on the Horner Automation website.

Module Setup Tab

- a) Input range may be set for each channel as +/-20 mA, 0-20 mA, 4-20 mA.
- b) Filter Constant sets the level of digital filtering according to the chart below.
- c) Reject Rates sets the frequency level for noise rejection at 50 or 60 Hz.

I/O Map Tab

The I/O Map describes which I/O registers are assigned to a specific SmartStack Module and where the module is located in the point map. The I/O Map is determined by the model number and location within the SmartStack. The I/O Map is not edited by the user.

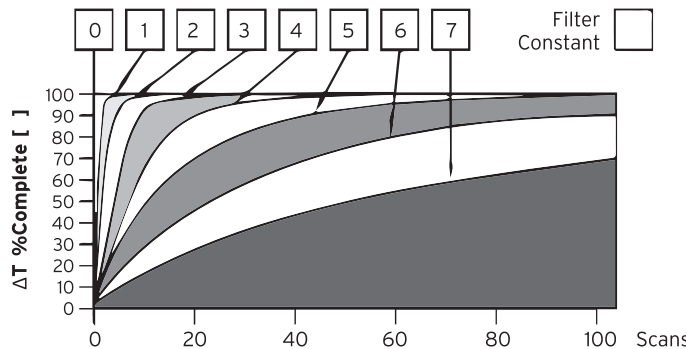

Digital Filtering: The illustration above demonstrates the effect of digital filtering (set with Filter Constant) on module response to a temperature change.

4 INPUT CONVERSION FACTOR

The following table describes how real-world inputs are scaled into the controller. Given a known input current, the data value is configured by using the conversion factor from the table.

The following formula is used: $\text{Data} = (\text{Current In (mA)} - \text{Offset}) / \text{Conversion Factor}$

Example: The user selects a current range of 4 to +20mA:

- 1) The known input current is 12 mA.
- 2) Using the table, the conversion factor for the range of 4-20mA is 0.0005 with an offset of 4mA.
- 3) To determine the data value, the formula is used:
 $\text{Data} = (\text{ma} - \text{Offset}) / \text{Conversion Factor}$
 $16000 = (12 \text{ mA} - 4 \text{ mA}) / 0.0005$

Conversion of Real-World Inputs into Controller					
	%AI Value				
Selected Range	Current In mA Dc	Data Out	LSB	Conversion Factor	Offset
+/-20mA	< -20.48mA	-32768 *	625µA	0.000625	0mA
	-20mA	-32000			
	0	0			
	+20mA	+32000			
	> +/-20.48mA	+32767 *			
0-20mA	< -20.48mA	0 *	625µA	0.000625	0mA
	-20mA	0			
	0	0			
	+20mA	+32000			
	> +/-20.48mA	+32767 *			
4-20mA	< -20.48mA	0 *	500µA	0.0005	4mA
	-20mA	0			
	4mA	0			
	+20mA	+32000			
	> +20.48mA	+32767 *			

* Digital output reading under overload condition.

5 SAFETY

SAFETY

- All applicable codes and standards should be followed in the installation of this product.
- Shielded, twisted-pair wiring should be used for best performance.
- In severe applications, shields should be tied directly to the ground block within the panel.
- Use the following wire type or equivalent: Belden 8441.

For detailed installation that covers panel box layout requirements and minimum clearances, refer to User Manual of controller.

WARNING - EXPLOSION HAZARD - DO NOT DISCONNECT EQUIPMENT UNLESS POWER HAS BEEN SWITCHED OFF OR THE AREA IS KNOWN TO BE NON-HAZARDOUS.

ATTENTION - RISQUE D'EXPLOSION - NE DÉBRANCHEZ PAS L'ÉQUIPEMENT SAUF SI L'ALIMENTATION A ÉTÉ COUPÉE OU SI LA ZONE N'EST PAS DANGEREUSE.

WARNING: Electrical Shock Hazard.

WARNINGS

1. To avoid the risk of electric shock or burns, always connect the safety (or earth) ground before making any other connections.
2. To reduce the risk of fire, electrical shock, or physical injury, it is strongly recommended to fuse the voltage measurement inputs. Be sure to locate fuses as close to the source as possible.
3. Replace fuse with the same type and rating to provide protection against risk of fire and shock hazards.
4. In the event of repeated failure, do NOT replace the fuse again as repeated failure indicates a defective condition that will NOT clear by replacing the fuse.
5. Only qualified electrical personnel familiar with the construction and operation of this equipment and the hazards involved should install, adjust, operate, or service this equipment. Read and understand this manual and other applicable manuals in their entirety before proceeding. Failure to observe this precaution could result in severe bodily injury or loss of life.

PRECAUTIONS

All applicable codes and standards need to be followed in the installation of this product. Adhere to the following safety precautions whenever any type of connection is made to the module:

1. Connect the safety (earth) ground on the power connector first before making any other connections.
2. When connecting to the electric circuits or pulse-initiating equipment, open their related breakers.
3. Do NOT make connection to live power lines.
4. Make connections to the module first; then connect to the circuit to be monitored.
5. Route power wires in a safe manner in accordance with good practice and local codes.
6. Wear proper personal protective equipment including safety glasses and insulated gloves when making connections to power circuits.
7. Ensure hands, shoes, and floor are dry before making any connection to a power line.
8. Make sure the unit is turned OFF before making connection to terminals.
9. Make sure all circuits are de-energized before making connections.
10. Before each use, inspect all cables for breaks or cracks in the insulation. Replace immediately if defective.

6 PART NUMBERS

The global part numbers are HE800ADC140, HE-ADC140 (plastic case).

7 TECHNICAL SUPPORT

For assistance and datasheet updates, contact Technical Support at the following locations:

North America

+1 (317) 916-4274
www.hornerautomation.com
techsppt@heapg.com

Europe

+353 (21) 4321-266
www.hornerautomation.eu
technical.support@horner-appg.com