



Sealed Panel Receptacles

For USB, 10/100 Ethernet, and RS-232/485

HE500RUK100, HE599RSF090, & HE599RUF090

with optional protective cover HE599CVR090

1 Available Receptacles

Available Models			
Receptacle Function	Connector 1	Connector 2	Part Number
USB "A"	Shielded USB "A" Female	Shielded USB "A" Female	HE500RUK100*
Ethernet 10/100	Shielded RJ45 Female	Shielded RJ45 Female	HE599RSF090
RS-232/RS-485	Unshielded RJ45 Female	Unshielded RJ45 Female	HE599RUF090

*Note: HE500RUK100 includes a 0.5m locking cable, USB A Male to USB A Male

2 Panel Mount Options

Rear Panel Mount

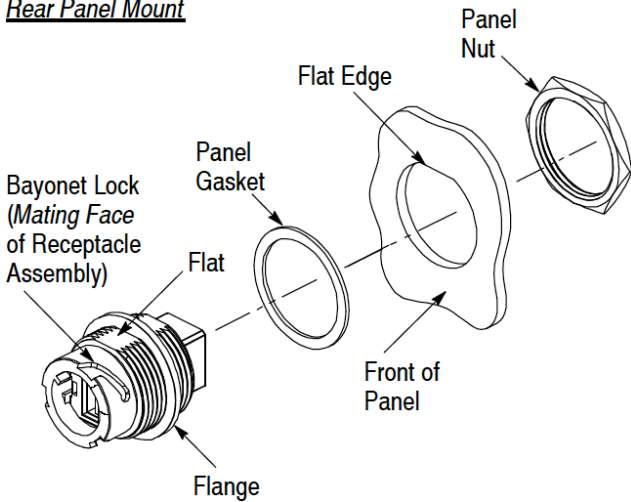

Front Panel Mount

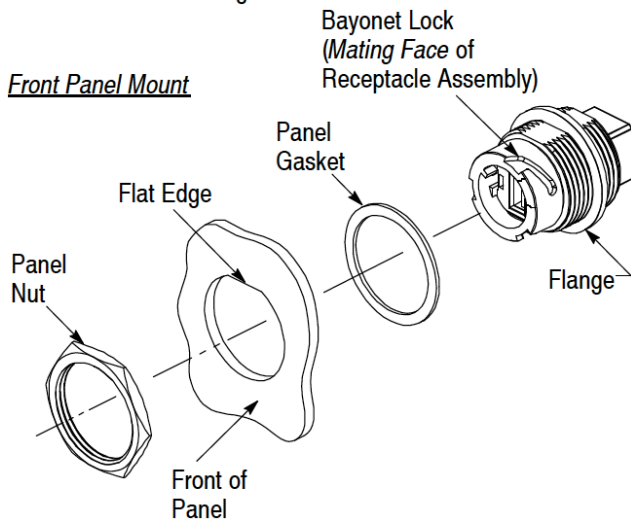

3 Panel Cutout

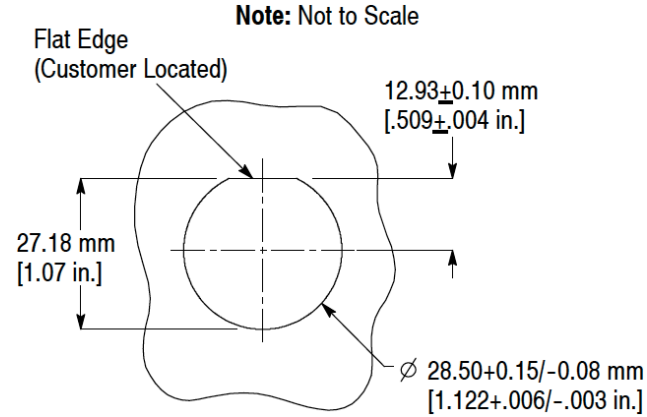

4 Optional Protective Cover (HE599CVR090)

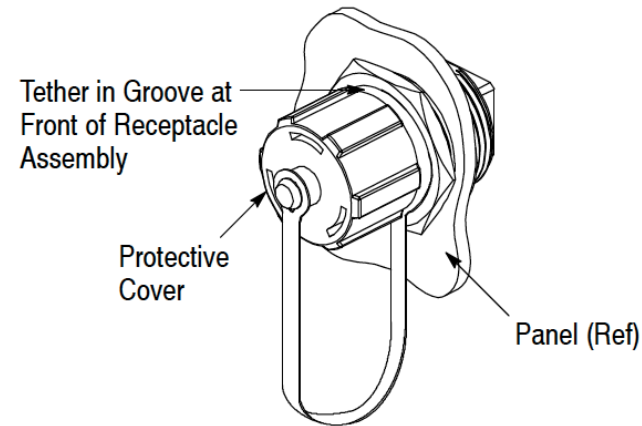

5 Installation / safety

Warning: Remove power from the OCS controller and any peripheral equipment connected to this local system before adding or replacing this or any component to the system.

a. All applicable codes and standards should be followed in the installation of this product.

When found on the product, the following symbols specify:



6 Technical Support

Technical Support at the following locations:

North America:
 Tel: 317 916-4274
 Fax: 317 639-4279
 Web: <http://www.heapg.com>
 Email: techsppt@heapg.com

Europe:
 Tel: +353-21-4321266
 Fax: +353-21-4321826
 Web: <http://www.horner-apg.com>
 Email: tech.support@horner-apg.com

No part of this publication may be reproduced without the prior agreement and written permission of Horner APG, Inc. Information in this document is subject to change without notice.