



D3
53mm
DIN rail mount



P44
48mmx48mm
panel mount



P49
48mmx96mm
panel mount

DC CURRENT MONITOR 5A or 1A CT incl 4-20mA or 0-10V re-transmit

D3-CMD0/1/2-T
P44-CMD0/1/2-T
P49-CMD0/1/2-T

EXAMPLE: D3-CMD0-T = 0 RELAY

Operating instructions and Guarantee Certificate
www.iconelectronics.co.za

ReTransmit devices (-T)

The 4 -20mA re-transmitted signal is optically isolated from the input signal. By default the re-transmission parameters are set so that the output follows the full scale input.

Description:

This device is used to display and monitor DC current. The 50mV DC input signal is displayed as the current through the shunt with up to 3 decimal places. Maximum & Minimum values are logged for 24 hours (updated every 60 min). The relay may be used for over and / or under protection. The latch facility may be de-activated for one or both the relays allowing one relay to be used for control (not latched), and the other as a latched alarm. Use the "ScAL" parameter for calibration purposes, or to change the number of decimal places displayed (see notes). Other features include adjustable signal damping, adjustable start-up and reaction delays, the ability to swap the relay's functionality. All settings may be locked & code protected to avoid changes from being made by unauthorised personnel.

0 RELAY DEVICE

The signal is displayed as 'real world' values.
(eg 0-100A ,not 0-50mV).

1 RELAY DEVICE

The signal is displayed as 'real world' values.(eg 0-100A ,not 0 -50mV). The relay remains energised while the input signal is between the upper and lower set points. Once de-energised, the signal must change in the opposite direction by the hysteresis amount before the relay will re-energise. Note: the relay will NOT re-energise while the **latch pins are shorted**. The latch pins can also be used as a reset.

2 RELAY DEVICE

The signal is displayed as 'real world' values.(eg 0-100A ,not 0 -50mV).The relays remain energised while the input signal is between the upper and lower set points. Once de-energised, the signal must change in the opposite direction by the hysteresis amount before the relay will re-energise. Either relay's action may be swapped to energise when the setpoint is reached. Note: the relay will NOT re-energise while the **latch pins are shorted**. The latch pins can also be used as a reset.

Adjustable parameters:

- **Upper limit for relay 1 "Hi 1"**
(default: disabled)
When the input rises above this value, the relay changes state until the signal drops by the hysteresis amount (see "HYS.1" setting)
- **Lower limit for relay 1 "Lo 1"**
(default: disabled)
When the input drops below this value, the relay changes state until the signal rises by the hysteresis amount (see "HYS.1" setting)
- **Hysteresis value for relay 1 "HYS.1"**
(default: 0.5)
Once the set-point is reached, (& relay changed state), the input signal must change (in the opposite direction) by this value before the relay will return to its original state.
- **Start-up delay for relay 1 "St.d.1"**
(default: 0.0 Sec, max: 100.0 Sec)
Delay (after power-up) before monitoring starts (to allow the signal to stabilize).
- **Reaction delay for relay 1 "rE.d.1"**
(default: 0.0 Sec, max: 100.0 Sec)
A fault condition must occur for longer than this period before the relay changes state. (To allow fault conditions for short periods of time)

- **Relay 1 function "rE.F.1"**
(default: De-energise)
Relay state when the setpoint is reached
"dE.En"=de-energise, "EnEr"= energise.
- **Latch enable for Relay "LA.t.1"**
(default: Enable)
When the setpoint is reached, & the relay has changed state, the relay will NOT revert back to the original state while the **latch pins are shorted** (with this parameter enabled), even if the measured value drops below the setpoint & hysteresis level. The latch pins can also be used to reset relay 1 if enabled. If disabled, the latch pins do NOT affect relay 1's functionality.
"En.Ab"=enabled, "diS.A"= disabled.
- **Upper limit for relay 2 "Hi 2"**
(default: disabled)
- **Lower limit for relay 2 "Lo 2"**
(default: disabled)
- **Hysteresis value for relay 2 "HYS.2"**
(default: 0.5)
- **Start-up delay for relay 2 "St.d.2"**
(default: 0 Sec, max: 100.0 Sec)
- **Reaction delay for relay 2 "rE.d.2"**
(default: 0 Sec, max: 100.0 Sec)
- **Relay 2 function "rE.F.2"**
(default: De-energise)
- **Latch enable for Relay 2"LA.t.2"**
(default: Enable)
- **Fault indication "indi"**
(default: on)
During fault conditions the display indicates whether the value is above or below the set point values ("r1.Hi","r1.Lo", "r2.Hi","r2.Lo"). If a fault condition exists, but the relay is being held energised by the start-up or reaction delay timers, "-r1-" or "-r2-" is displayed. Changing this setting to "off", disables these messages. Note:This setting does not affect the "Er.Hi" and "Er.Lo" messages. (see notes)
- **Lower display value "diSP"**
Select the value to be displayed on the lower LED display.
"Hi 1", "Lo 1" or "off"
- **24 hour Minimum "24h.L"**
Display the lowest value measured during the past 24 hours
(Press "SELECT" to clear)

Menu operation

(single display device):

All adjustments are made via the three front mounted buttons. Press the "MENU" button repeatedly until the desired setting is reached, press "SELECT" to display the current value of the selected parameter, or sub menu (if applicable). The "+" and "-" buttons are used to change the value. "ENTER" will return the device to the menu. The "BACK" button will exit the menu.

Menu operation

(dual display device):

Press the menu "⏏" button repeatedly until the desired setting is reached. The "▲" and "▼" buttons are used to change the value. "⏏" will display the next menu item. To exit the menu hold "⏏" button for 3 seconds.

Menu options:

Exit the menu before making the following adjustments.

Lock / unlock parameters:

(default: unlocked)

Press "BACK" ("▼"), then "ENTER" ("⏏") and hold the 2 buttons until the desired option is displayed. The display cycles between "Loc" (no changes allowed) & "u.Loc" (parameters may be adjusted)

Full / reduced menu (default: Full)

Press "SELECT"("▲"), then "ENTER"("⏏") and hold the 2 buttons until the desired option is displayed. The display cycles between "rEdu" (limited menu) & "Full" (all parameters are accessible)

Access Code: (default: no code)

Once the above options have been set as required, Press "BACK" and "SELECT" ("▼" and "▲") simultaneously until "CODE" is displayed. Now use the "+" & "-" ("▲" and "▼") to enter a code. Once a code is entered, access to the options above is not permitted. To clear the code, re-enter the same code again. If the code is forgotten. Press and hold "+" & "-"

• 24 hour Maximum “24h.h”

Display the highest value measured during the past 24 hours
(Press “SELECT” to clear)

• Display Span “SCAL” (default value:100.0)

This value is displayed when 50mV is applied to the input. Set this value to match the shunt being used.

• Decimal pointer “dEci” (default value: 100.0)

Use this setting to adjust the decimal point to the desired position.
(0.000/0.00/0.0/0)

• Software damping filter “FiLt” (default value:6)

Adjust from 1 to 15 to increase the amount of signal damping.

• Re-transmit output Offset “rt.OS”

(default value: programmed display offset value)
When the display indicates this value, 4mA will be transmitted.

• Re-transmit output SPan “rt.SP”

(default value: programmed display span value)
When the display indicates this value PLUS the offset value (“rt.SP”+“rt.OS”), 20mA is transmitted.

• Reset “RESt”

By selecting this setting, the device is reset to the factory defaults press “▲”and “▼” together to select.

DUAL DISPLAY DEVICE Programming Example1:

Set the device to de-energise relay 1 when the current is below 10.0A and above 90.0A (100A shunt)

If all of the following settings are NOT available, exit the menu and activate the advanced menu.

Press “U” to display “Hi 1”.

Use “▲”and “▼” buttons to change the value to “90.0”.

Press “U” to display “Lo 1”.

Use “▲”and “▼” buttons to change the value to “10.0”.

Press and hold “U” for 3 seconds to exit the menu.

DUAL DISPLAY DEVICE Programming Example2:

Set the device to display 0-150.0A for a voltage of 0-50mV ie: 0V=0A, 50mV=150.0A

Press “U” repeatedly until “SCAL” is displayed.

Use “▲”and “▼” buttons to change the value to “1500”.

Press “U” to display “dEci”.

Use “▲”and “▼” buttons to move the decimal pointer to the desired position.

Press and hold “U” for 3 seconds to exit the menu.

SINGLE DISPLAY DEVICE Programming Example1:

Set the device to de-energise relay 1 when the current is below 10.0A and above 90.0A (100A shunt)

If all of the following settings are NOT available, exit the menu and activate the advanced menu.

Press “MENU” to display “Hi 1”.

Press “SELECT” and change the value to “90.0”.

Press “ENTER”. “Lo 1” is displayed.

Press “SELECT” and change the value to “10.0”.

Press “ENTER”.

Press “BACK” to exit the menu.

SINGLE DISPLAY DEVICE Programming Example2

Set the device to display 0-150.0A for a voltage of 0-50mV ie: 0V=0A, 50mV=150.0A

Press “MENU” repeatedly until “SCAL” is displayed.

Change the value to 1500.

Press “ENTER”. “dEci” is displayed.

Press “SELECT” and move the decimal pointer to the desired position.e)

Notes:

- Whenever the input signal is above or below the “CAL.O” or “CAL.S” values by more than 3%. The display indicates “Er.Hi” or “ER.Lo”.
- The maximum & minimum values are NOT updated during the first 30 seconds after power up. This allows the input signal to stabilize first.

Specifications:

- Display scale: 10 to 9999
- Display resolution: 0.01 to 1.000 (adjustable)
- Measurement resolution: 50 uV
- Accuracy: ±0.3% @ 25°C (% of full scale)
- Input voltage: ±15% of rated input

re-transmit Notes:

- The output 4-20mA is dependant on the value being displayed, and is set up in a similar manner to the display. The offset parameter determines when 4mA is output, and the span is the amount required for the output to increase by an additional 12mA ie. 20mA is output when the value displayed = re-transmit OFFSET+SPAN
- To set the re-transmission signal to follow the input signal (the output 4-20mA follows the 4-20mA received), set the re-tx offset and span settings to the same value as the display offset and span settings.
- To set the re-transmission signal to invert the input signal (the output = 4mA when the input = 20mA), set the re-tx offset = (display offset+span) and re-tx span = (display span x -1).
- Whenever the input signal is above or below the “CAL.O” or “CAL.S” values by more than 3%. The display indicates “Er.Hi” or “ER.Lo”.
- Certain settings are reset to default when the device is re-configured. Re-check all settings to ensure they are correct before commissioning. (use the advanced menu)

Please Note (for 1 and 2 relay devices ONLY):

- As a power saving feature, the display dims if settings are not being made.
- Even though the device seems to operate correctly, the relay(s) will not energise if the input voltage is below the operating voltage.

12 Month guarantee:

Our product is guaranteed for a 12 (twelve) month period from date of purchase. This guarantee is valid for defects arising from failure during specified conditions. This guarantee does not cover damage due to abuse, tampering or improper installation. Our company does not accept liability for any consequential damage or loss arising from product malfunction. Should this product prove to be defective, kindly return for inspection or repair.

Relay specifications:

- Contact rating: 10A 250 VAC 2500VA
- Mechanical life: 30 million operations
- Electrical life: 250 000 operations (at maximum load)

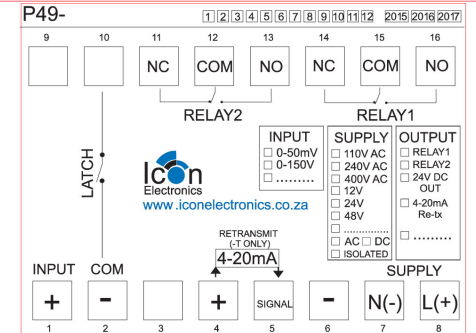
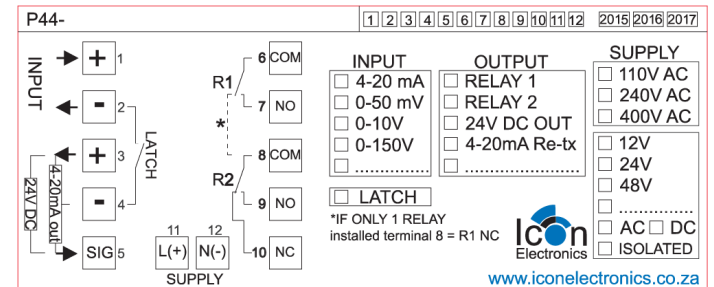
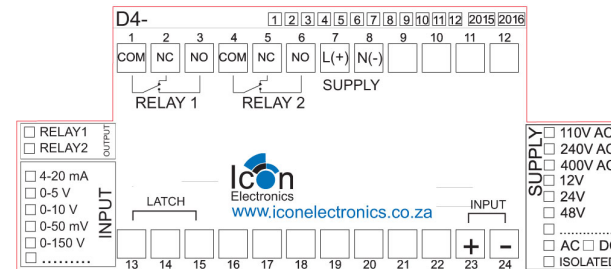
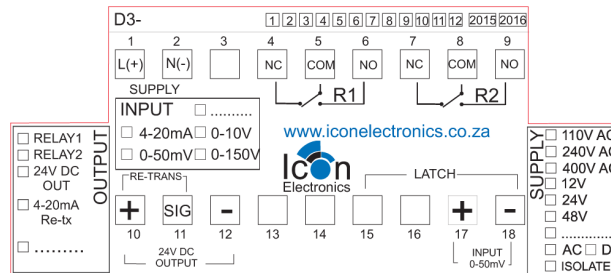

For further information, please visit us at: www.iconelectronics.co.za