



COUNTIS E3x

Active energy meters

three-phase - direct 100 A

Single-circuit metering,
measurement &
analysis



COUNTIS E32 - MID

Function

The **COUNTIS E3x** is a modular energy meter displaying the energy and power consumed (kWh and kW) directly on its backlit LCD display. It is designed for three-phase load metering and is used for direct connections of up to 100 A.

COUNTIS E32, E34 and E36 are MID certified.

Common characteristics

- Measurement accuracy: 1 %
- Backlit LCD display.
- Detects connection errors.

Advantages

RS485 communication (MODBUS or M-BUS) or pulse output

To enable the remote reporting of energy consumption, COUNTIS E3x are provided with either a pulse output or an RS485 communication output, with MODBUS or M-BUS protocol.

In addition to their reporting functions, COUNTIS E3x with RS485 can be configured remotely and enable access to multi-measurement values.

Detection of connection errors

The product is protected against phase/neutral inversion and detects wiring errors. This simplifies the installation and commissioning, thereby reducing associated costs, and ensures that the device operates correctly.

Principle diagram

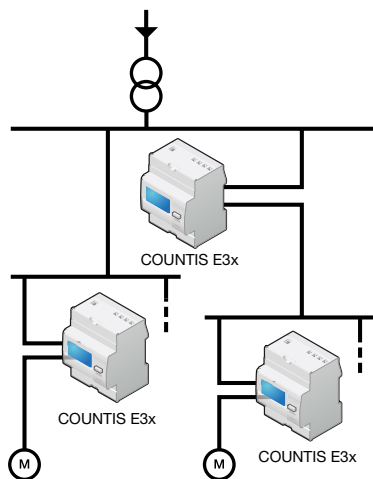

count_225_a_1_x_cat

MID certified B+D module

COUNTIS E products with MID certification provide the guaranteed accuracy required for applications in which sub-billing of the electrical energy consumed is necessary. "Module B+D" certification guarantees that the design and manufacturing process of products are approved by an accredited laboratory.

Bi-directional metering (available only on the E33 and E35)

This function is for metering energy production or energy consumption.

Multi-measurement and load curve

Display of electrical values (I, U, V, P, Q, S, PF) and load curve over a 7 day period via communication.

The solution for

- Industry
- Infrastructure
- Data centre



Strong points

- RS485 communication (MODBUS or M-BUS) or pulse output
- Detection of connection errors
- MID certified B+D module
- Bi-directional metering
- Multi-measurement and load curve

MID certification

- COUNTIS E comply with the MID directive, guaranteeing accuracy and reliability when metering, an indispensable function for energy billing applications.
- COUNTIS E MID feature tamper-proof components to prevent fraud.



Conformity to standards

- IEC 62053-21 class 1
- IEC 62053-31
- IEC 62053-11
- EN 50470-1
- EN 50470-3



Models	Key characteristics
E30	Pulse output
E31	Dual tariff (2 partial counters) + Pulse output
E32	Dual tariff + MID + Pulse output
E33	Dual tariff + RS485 MODBUS communication
E34	Dual tariff + RS485 MODBUS communication + MID
E35	Dual tariff + M-BUS communication
E36	Dual tariff + M-BUS communication + MID

Front panel



1. Terminal shrouds (COUNTIS E32, E34 and E36).
2. Backlit LCD display.
3. MID marking (COUNTIS E32, E34 and E36).
4. Serial number (COUNTIS E32, E34 and E36).
5. Navigation key.
6. Reset key.
7. Metrological LED.

Dimensions (mm)

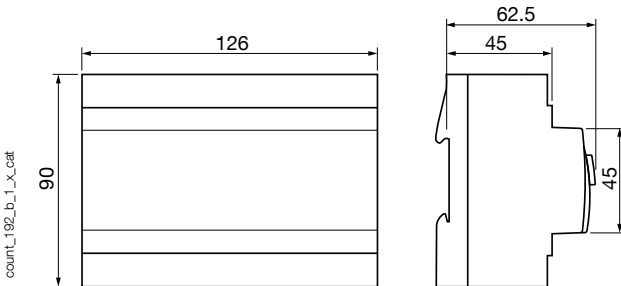

Type	modular
Number of modules	7
Dimensions W x H x D	126 x 90 x 62.5 mm
Case degree of protection	IP20
Front degree of protection	IP51
Display type	backlit LCD display
Rigid cable cross-section	2.5 ... 35 mm ²
Flexible cable cross-section	2.5 ... 35 mm ²
Weight	490 g

Electrical characteristics

Current measurement

Type	three-phase - direct 100 A
Input consumption	0.5 VA max. per phase
Startup current (I_{st})	80 mA
Minimum current (I_{min})	0.5 A ⁽¹⁾
Transition current (I_{tr})	2 A ⁽²⁾
Reference current (I_{ref})	20 A ⁽³⁾
Permanent overload (I_{max})	100 A
Intermittent overload	3000 A max for 10 ms

Voltage measurement

Range of measurement	230 ... 400 V \pm 20 %
Consumption (VA)	2
Permanent overload	280 V phase-neutral / 480 V phase-phase

Energy accuracy

Active (according to IEC 62053-21)	Class 1
Active (according to EN 50470)	Class B

Power supply

Self-supplied	yes
Frequency	50 / 60 Hz

Output (pulsed) (COUNTIS E30/E31/E32)

Number	1
Type of optocoupler	IEC 62053-31 class A (20 ... 30 VDC)
Fixed pulse weight	100 Wh
Pulse duration	100 ms

Operating conditions

Operating temperature	-10 ... 55 °C
Storage temperature	-20 ... 70 °C
Relative humidity	85 %

Communication	COUNTIS E33/34	COUNTIS E35/E36
Link	RS485	Connection
Type	2 half duplex wires	2 half duplex wires
Protocol	MODBUS RTU	M-BUS
Speed	4800 ... 38 400 bauds	300 ... 9600 bauds

(1) $I_{min} \leq 0.5 \cdot I_{tr}$

(2) The accuracy class is guaranteed between I_{tr} and I_{max} .

(3) $I_{ref} = I_{tr}$ (base current) = $10 \cdot I_{tr}$ for direct connection COUNTIS.

Connection

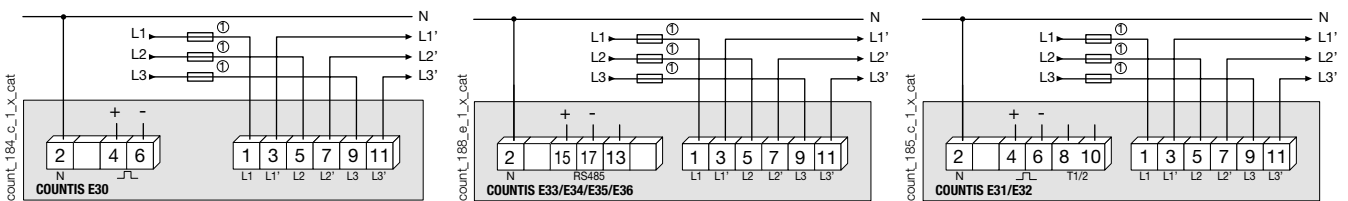

1. 100 A gG / Am fuses max.

References

Type	COUNTIS E30 Reference	COUNTIS E31 Reference	COUNTIS E32 Reference	COUNTIS E33 Reference	COUNTIS E34 Reference	COUNTIS E35 Reference	COUNTIS E36 Reference
100 A direct	4850 3005						
100 A direct - Dual tariff		4850 3006					
100 A direct - Dual tariff + MID			4850 3007				
100 A direct - Dual tariff + MODBUS communication via RS485 ⁽¹⁾				4850 3012			
100 A direct - Dual tariff + MODBUS communication via RS485 + MID ⁽¹⁾					4850 3013		
100 A direct - Dual tariff + M-Bus communication ⁽¹⁾						4850 3025	
100 A direct - Dual tariff + M-Bus communication + MID ⁽¹⁾							4850 3026

(1) 4 tariffs through RS485 communication.