



SIRIUS Compact load feeder Reversing starter for IO-Link 400 V 24 V DC 8...32 A
IP20 Connection main circuit: plug-in, without terminals Connection control circuit:
screw terminal

product brand name	SIRIUS
product designation	Compact starter for IO-Link
design of the product	reversing starter
product type designation	3RA65
General technical data	
product function control circuit interface to parallel wiring	No
product extension auxiliary switch	Yes
power loss [W] for rated value of the current	
• at AC in hot operating state	5.4 W
• at AC in hot operating state per pole	1.8 W
• without load current share typical	3.4 W
insulation voltage rated value	690 V
degree of pollution	3
surge voltage resistance rated value	6 000 V
degree of protection NEMA rating	other
shock resistance	a=60 m/s ² (6g) with 10 ms per 3 shocks in all axes
mechanical service life (operating cycles)	
• of the main contacts typical	10 000 000
• of auxiliary contacts typical	10 000 000
• of the signaling contacts typical	10 000 000
electrical endurance (operating cycles) of auxiliary contacts	
• at DC-13 at 6 A at 24 V typical	30 000
• at AC-15 at 6 A at 230 V typical	200 000
type of assignment	continuous operation according to IEC 60947-6-2
reference code according to IEC 81346-2	Q
Substance Prohibitance (Date)	05/01/2012
SVHC substance name	Blei - 7439-92-1 Bleimonoxid (Bleioxid) - 1317-36-8 Bleitanzirkonoxid - 12626-81-2 2,2',6,6'-Tetrabrom-4,4'-isopropylidendi - 79-94-7
Ambient conditions	
installation altitude at height above sea level maximum	2 000 m
ambient temperature	
• during operation	-20 ... +60 °C
• during storage	-55 ... +80 °C
• during transport	-55 ... +80 °C
relative humidity during operation	10 ... 90 %
Main circuit	
number of poles for main current circuit	3
adjustable current response value current of the current-dependent overload release	8 ... 32 A

formula for making capacity limit current	12 x I _e
formula for limit current breaking capacity	10 x I _e
yielded mechanical performance for 4-pole AC motor	
• at 400 V rated value	15 kW
operating voltage at AC-3 rated value maximum	400 V
operational current	
• at AC at 400 V rated value	32 A
• at AC-3 at 400 V rated value	32 A
• at AC-43	
— at 400 V rated value	29 A
operating power	
• at AC-3 at 400 V rated value	15 kW
• at AC-43	
— at 400 V rated value	15 000 W
no-load switching frequency	3 600 1/h
operating frequency	
• at AC-41 according to IEC 60947-6-2 maximum	750 1/h
• at AC-43 according to IEC 60947-6-2 maximum	250 1/h
Control circuit/ Control	
type of voltage	DC
control supply voltage 1	
• at DC rated value	24 V
• at DC	24 ... 24 V
holding power	
• at DC maximum	3.4 W
Auxiliary circuit	
number of NC contacts for auxiliary contacts	0
number of NO contacts for auxiliary contacts	0
number of NO contacts of instantaneous short-circuit trip unit for signaling contact	0
number of CO contacts of the current-dependent overload release for signaling contact	0
operational current of auxiliary contacts at AC-12 maximum	10 A
operational current of auxiliary contacts at DC-13 at 250 V	0.27 A
Protective and monitoring functions	
trip class	CLASS 10 and 20 adjustable
operating short-circuit current breaking capacity (I_{cs})	
• at 400 V	53 kA
UL/CSA ratings	
full-load current (FLA) for 3-phase AC motor	
• at 480 V rated value	32 A
yielded mechanical performance [hp] for 3-phase AC motor	
• at 200/208 V rated value	7.5 hp
• at 220/230 V rated value	10 hp
• at 460/480 V rated value	20 hp
Short-circuit protection	
product function short circuit protection	Yes
design of short-circuit protection	electromagnetic
design of the fuse link	
• for short-circuit protection of the auxiliary switch required	fuse gL/gG: 10 A
Installation/ mounting/ dimensions	
mounting position	any
• recommended	vertical, on horizontal standard DIN rail
fastening method	screw and snap-on mounting
height	170 mm
width	90 mm
depth	165 mm
Connections/ Terminals	
product component removable terminal for main circuit	Yes
product component removable terminal for auxiliary and control circuit	Yes

type of electrical connection	
<ul style="list-style-type: none"> • for main current circuit • for auxiliary and control circuit 	<p>plug-in without terminals</p> <p>screw-type terminals</p>
type of connectable conductor cross-sections for main contacts	
<ul style="list-style-type: none"> • solid • finely stranded with core end processing 	<p>2x (2.5 ... 6 mm²), 1x 10 mm²</p> <p>2x (2.5 ... 6 mm²)</p>
type of connectable conductor cross-sections	
<ul style="list-style-type: none"> • for auxiliary contacts <ul style="list-style-type: none"> — solid — finely stranded with core end processing • for AWG cables for auxiliary contacts 	<p>0.5 ... 4 mm², 2x (0.5 ... 2.5 mm²)</p> <p>0.5 ... 2.5 mm², 2x (0.5 ... 1.5 mm²)</p> <p>2x (20 ... 14)</p>

Safety related data

proportion of dangerous failures	
<ul style="list-style-type: none"> • with high demand rate according to SN 31920 	50 %
B10 value with high demand rate according to SN 31920	1 500 000
protection class IP on the front according to IEC 60529	IP20
touch protection on the front according to IEC 60529	finger-safe

Communication/ Protocol

product function bus communication	Yes
protocol is supported	
<ul style="list-style-type: none"> • AS-Interface protocol • IO-Link protocol 	<p>No</p> <p>Yes</p>
product function control circuit interface with IO link	Yes
IO-Link transfer rate	COM2 (38,4 kBaud)
point-to-point cycle time between master and IO-Link device minimum	2.5 ms
type of voltage supply via input/output link master	No
data volume	
<ul style="list-style-type: none"> • of the address range of the inputs with cyclical transfer total • of the address range of the outputs with cyclical transfer total 	<p>2 byte</p> <p>2 byte</p>

Electromagnetic compatibility

conducted interference	
<ul style="list-style-type: none"> • due to burst according to IEC 61000-4-4 • due to conductor-earth surge according to IEC 61000-4-5 • due to conductor-conductor surge according to IEC 61000-4-5 • due to high-frequency radiation according to IEC 61000-4-6 	<p>4 kV main circuits, 2 kV auxiliary circuits, 2 kV IO-Link, 2 kV limit switches, 2 kV line hand-held device</p> <p>4 kV main circuits, 0.5 kV auxiliary voltage with upstream overvoltage protection</p> <p>2 kV main circuits, 0.5 kV auxiliary voltage with upstream overvoltage protection</p> <p>0.15-80Mhz at 10V</p>
field-based interference according to IEC 61000-4-3	80 ... 3000 MHz at 10V/m
electrostatic discharge according to IEC 61000-4-2	8 kV
conducted HF interference emissions according to CISPR11	150 kHz ... 30 MHz Class A
field-bound HF interference emission according to CISPR11	30 ... 1000 MHz Class A

Supply voltage

Supply voltage required Auxiliary voltage	Yes
--	-----

Display

number of LEDs	5
display version as status display of the input/output link device	green/red dual LED

Approvals Certificates

General Product Approval	EMC	Functional Safety/Safety of Machinery
---------------------------------	------------	--

[Confirmation](#)



Declaration of Conformity	Test Certificates	Marine / Shipping
----------------------------------	--------------------------	--------------------------



[Type Test Certificates/Test Report](#)



other	Dangerous Good
-------	----------------

[Confirmation](#)

[Transport Information](#)

Further information

Siemens has decided to exit the Russian market (see here).

<https://press.siemens.com/global/en/pressrelease/siemens-wind-down-russian-business>

Siemens is working on the renewal of the current EAC certificates.

Please contact your local Siemens office on the status of validity of the EAC certification if you intend to import or offer to supply these products to an EAC relevant market (other than the sanctioned EAEU member states Russia or Belarus).

Information on the packaging

<https://support.industry.siemens.com/cs/ww/en/view/109813875>

Information- and Downloadcenter (Catalogs, Brochures,...)

<https://www.siemens.com/ic10>

Industry Mall (Online ordering system)

<https://mall.industry.siemens.com/mall/en/en/Catalog/product?mlfb=3RA6500-1EB43>

Cax online generator

<http://support.automation.siemens.com/WW/CAXorder/default.aspx?lang=en&mlfb=3RA6500-1EB43>

Service&Support (Manuals, Certificates, Characteristics, FAQs,...)

<https://support.industry.siemens.com/cs/ww/en/ps/3RA6500-1EB43>

Image database (product images, 2D dimension drawings, 3D models, device circuit diagrams, EPLAN macros, ...)

http://www.automation.siemens.com/bilddb/cax_de.aspx?mlfb=3RA6500-1EB43&lang=en

Characteristic: Tripping characteristics, I_t, Let-through current

<https://support.industry.siemens.com/cs/ww/en/ps/3RA6500-1EB43/char>

Further characteristics (e.g. electrical endurance, switching frequency)

<http://www.automation.siemens.com/bilddb/index.aspx?view=Search&mlfb=3RA6500-1EB43&objecttype=14&gridview=view1>

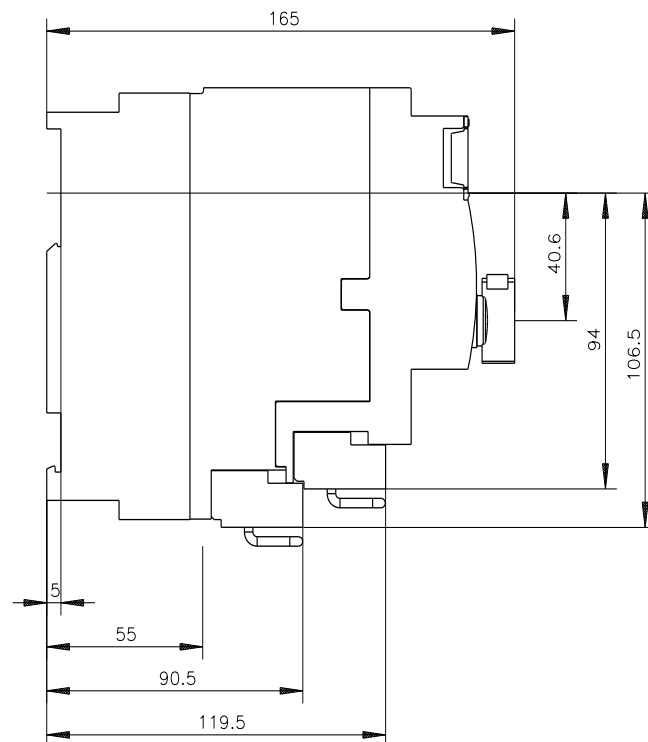
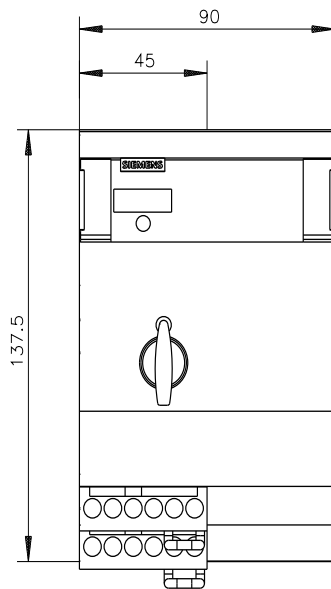

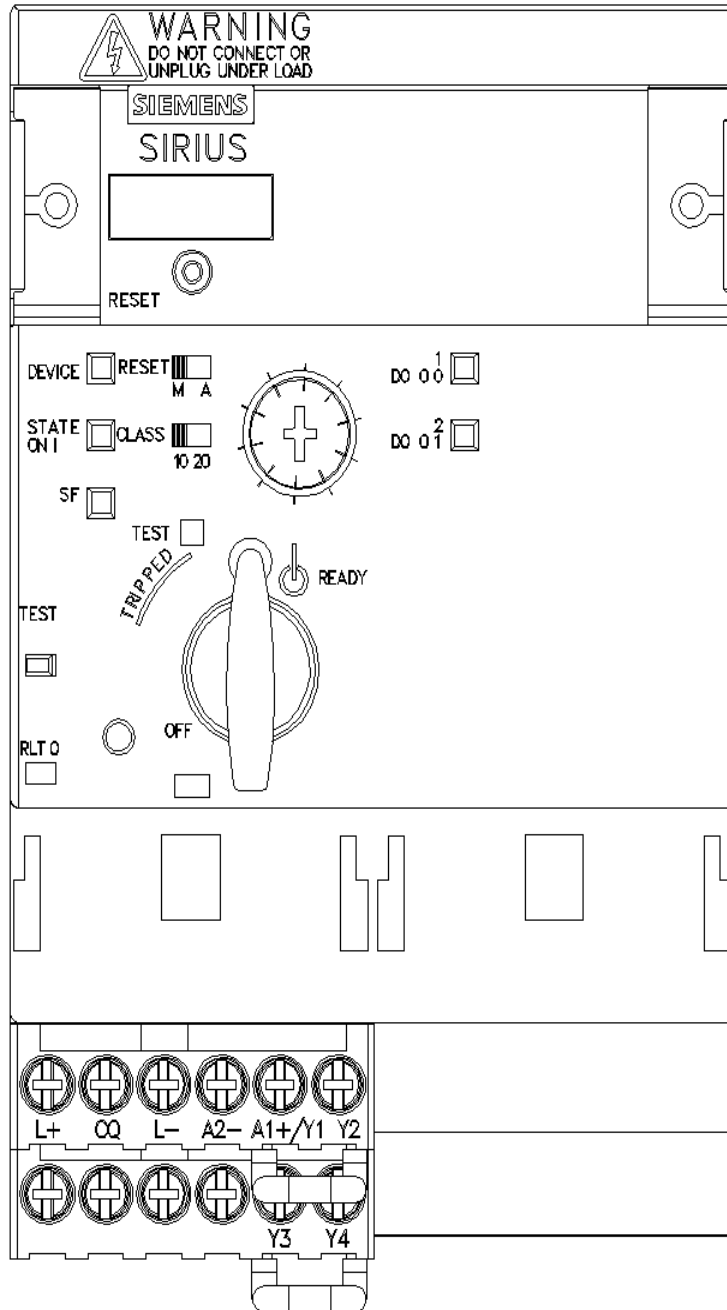

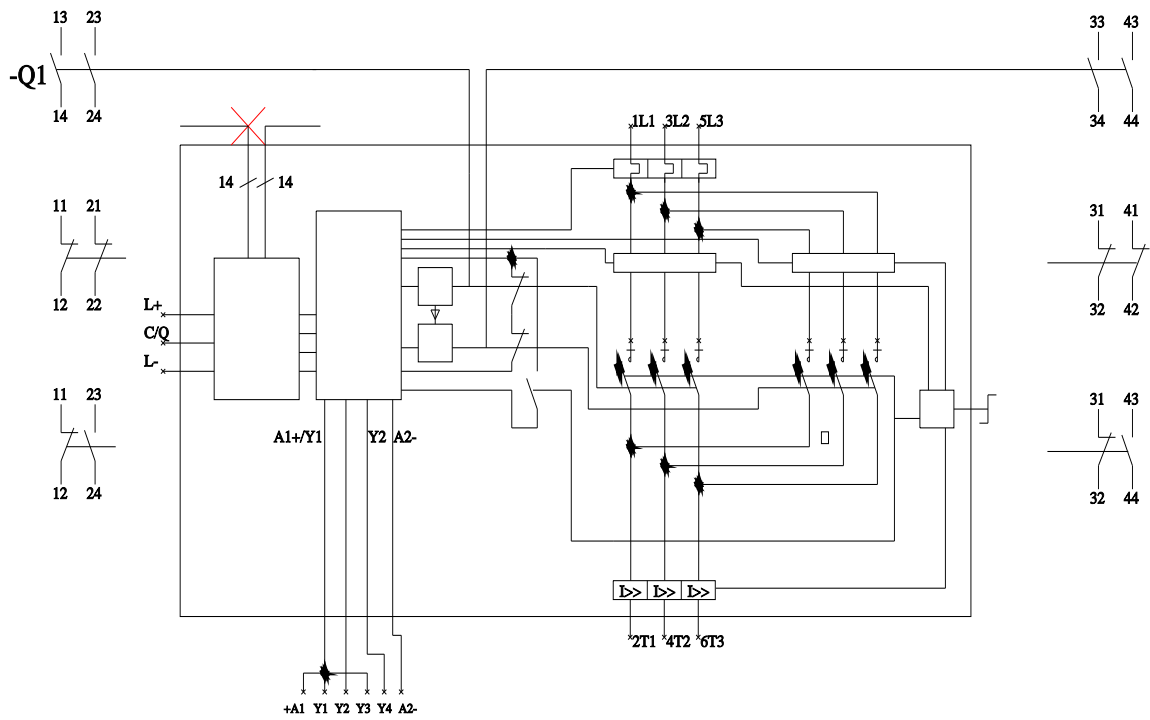

last modified:

8/7/2023